

SMB2 Super Mystère / IAI Sa'ar

Instructions / Návod

EN

The French Dassault Super Mystère B2 was the first Western European, mass production-built jet fighter to achieve supersonic speed in a level flight. The type was a follow-on development of Dassault's earlier successful jet fighter airplanes such as the Ouragan or Mystère IV and a number of test prototypes too. The first prototype Super Mystère, designated the SMB1 first flew on 2 March 1955. In spite of the plane possessing rather superb performance, the French Air Force refused to use the type – as the production SMB1s were to be powered by a French licence copy of the British R&R Avon RA-21 turbojet and it was feared that it would take far too much time to introduce the licence production in France. Dassault, however, had already had another ace up their sleeve – this being a project of a truly French version of the Super Mystère powered by an Atar 101G-1 turbojet with a reheat. The first prototype of this plane, known as the SMB2 01 was taken aloft for the first time by Dassault's factory pilot Gérard Muselli. The new type's behaviour and characteristics were tested using five airframes, but the production had already been ordered, in actual fact yet before the prototype first flew. The first production airframe, out of the total of 180 built, first flew on 26 February 1957, with the production machines being allocated to No.10, 12 and 5 escadrons of the Armée de l'Air, they also served with test centres CEV and CEAM and in flying schools. Later machines were fitted with more powerful Atar 101G-2 or G-3 engines. The type was on strength of combat squadrons until 1977 when the last remaining SMB2s of No.12 Escadron were replaced by more modern Mirage III jets. The service of SMB2s with the French military was quite uneventful, the only exception to the dull military routine were the occasional air force exercises which took place in NATO countries or in Africa and also the Operation Air Bull in Thailand.

The most important operator of the type outside of France, the Israel Air Force saw much more interesting flying and combat career of the type – their SMB2s took part in a series of clashes, conflicts and wars between Israel and its Arab neighbours. These wars are known as the War over Water, Six Day War, Yom Kippur War and also the rather lengthy conflict between these „regular“ wars, the Attrition War. The State of Israel had placed the order for the SMB2 fighters already in 1956, this being confirmed only two years later, in 1958. The SMB2, locally known as the Sambad, were delivered in two batches of 24 and 12 airframes. Seven more of them were delivered later to make up for losses suffered during the service. Soon after the Sambads had been delivered, Israel acquired also the excellent Mirage IIIC jets which became its major front line fighter aircraft, so the Sambads were deployed just to one Tayeset, or Squadron (the 105th) and flew mainly in the fighter-bomber role. Sambads excelled in the amount of external stores and armament they were able to carry and deliver to the target, but once this lethal cargo dropped, they were also perfectly capable of performing the fighter role. They were particularly dangerous opponents at low levels where they could easily tackle even a generation-younger MiG-21 jets. The Israeli Sambads have six aerial victories under their belt, including a pair of MiG-21s, a Mi-6 helicopter, large number of aircraft and military vehicles destroyed on the ground and also two Egyptian torpedo boats. While in France the further development of the SMB2 was ceased in favour of more modern Mirage III aircraft (except for two prototypes of more powerful SMB4 version equipped with the Atar 9 engine), the operational life of Israeli airframes was made substantially longer by the installation of a new engine. Owing to the trouble with spare parts caused by the French arms embargo, the Israeli Aircraft Industries (IAI) proposed to fit the already rather worn out airframes with the US-built J52 turbofan. Even though these powerplants lacked the reheat, they were 25% lighter, had lower fuel consumption and offered thrust almost comparable to their French counterparts (Atar 9,900lb, J52 9,300lb). As the new unit weighed less, it had to be mounted further back in the rear fuselage and as the nozzle was also already longer, it resulted in much longer jet pipe of the new machines compared to the standard Sambad. In the end, this change proved to help the type's survivability after being hit by enemy's IR-guided anti-aircraft missiles – the missiles homed usually on the hot exhaust nozzle and when exploded, the war head fragments did not hit the tail control surfaces as lethally as was the case with the standard, short tailed Sambad type. The performance remained almost the same, except for acceleration and initial rate of climb. What is more, the type could carry much more underwing stores, had much larger range and could operate in the combat area much longer. In total, 26 airframes were re-engined and they were known in the IAF as the Sa'ar, or Storm in Hebrew. In a short time, they got the opportunity to show their capabilities in the 1973 Yom Kippur War and excelled in the ground attack role. In 1975, the 105th Tayeset received their new F-4 Phantom II jets and the already obsolete Sa'ars finally retired. Two of them were put on display at the IAF museum, the remaining 18 airframes were overhauled, fitted with a new hot seat and eventually sold to Honduras where they were the backbone of the country's air defence and flew well until the 1990s when being replaced by the F-5 Tiger jets. The Honduran Sa'ar can boast themselves with downing several aircraft of drug cartels and a Nicaraguan Mi25 helicopter.

Wingspan: 10.51 m, length: 14.13 m, top speed at sea level/ at 12,000 m: 1.038 kmh / 1.189 kmh (1.12 Mach), range with external tanks: 1,790 km, ceiling: 16,667 m.

CZ

SMB-2 Super Mystère byl prvním velkosériově vyráběným západoevropským letounem, který překonal rychlost zvuku ve vodorovném letu. Firma Dassault při jeho vývoji navázala na své předchozí sériově vyráběné stíhací typy Ouragan a Mystère IVB a množství pokusných prototypů. První prototyp Super Mystère s označením SMB-1 vzletěl 2. března 1955. Francouzské letectvo jej, přes vysoké výkony do výzbroje nepřijalo. Poháněj je totiž anglický motor R&R Avon RA-21. Rozběh licenční výroby tohoto motoru by trval dlouho. Dassault ale měl připraven návrh verze s francouzským motorem Atar 101G-1 s přídavným spalováním. 15.5. 1956 vzletěl poprvé prototyp SMB-2 01, pilotován továrním pilotem G. Musellim. Vlastnosti nového letounu byly testovány na pěti prototypech. Sériová výroba byla objednána ještě před vzletem prototypu. První sériový letoun, ze 180 vyrobených, byl zalétán 26.2. 1957. Nové letouny byly postupně zařazeny k třem escadrám Armée de l'Air, čísel 10, 12 a 5, létaly také u testovacích středisek CEV a CEAM a v leteckých školách. Pozdější vyrobené kusy SMB-2 dostávaly výkonnější motor Atar 101G-2 nebo G-3. U bojových escader létaly Super Mystère až do roku 1977, kdy byly vyřazeny poslední SMB-2 escadry 12 a nahrazeny stroji Mirage III. Služba SMB-2 Armée de l'Air byla relativně poklidná, spěstřená cvičeními ve státech NATO, v Africe a účastí na operaci Air Bull v Thajsku.

U druhého uživatele, izraelského letectva, to bylo přesně naopak. Služba SMB-2 v IAF byla spěstřena účastí v sérii konfliktů s arabskými sousedy Izraele, pojmenovaných Válka o vodu, Šestidenní válce, válce Jom-Kippur a vleklým konfliktem mezi těmito válkami, tzv. opotřebovací válkou. Izrael objednal SMB-2 již v roce 1956, v roce 1958 byla objednávka potvrzena. SMB-2, v Izraeli pojmenované Sambad, byly dodány ve dvou dodávkách, po 24 a 12 kusech. Později bylo dodáno ještě sedm kusů jako náhrada ztrát. Brzy po Sambadech byly do Izraele dodány vynikající Mirage IIIC, které se staly hlavními prvoliniovými stíhačkami. Sambady byly proto přiděleny jen jedné jednotce 105. tajeset a byly používány hlavně jako stíhací bombardéry. Vynikaly nosností podvěšené výzbroje. Ale po jejím odhození se stávaly plnohodnotnými stíhačkami. Byly, zejména v malých výškách, nebezpečnější i o generaci mladším Migům 21. Na kontě Sambadů je šest sestřelů, včetně dvou Migů 21 a vrtulníku Mi-6, množství letecké a pozemní techniky zničené na zemi a také dvě egyptské torpédovky.

Zatímco ve Francii byl vývoj Super Mystère mimo dvou prototypů výkonnější verze SMB-4 s motorem Atar 9 zastaven ve prospěch modernějších Mirage III, v Izraeli se část letounů dočkala přestavby na nový motor. Pro potíže s dodávkami náhradních motorů Atar zabudovala firma IAI do všech zbývajících SMB-2 americké motory J-52. Ty sice neměly přídavné spalování, ale byly lehčí a měly o 25% vyšší výkon při nižší spotřebě paliva. Motory J-52 měly proti Ataru delší trysku. Díky tomu byl prodloužen trup za ocasními plochami. To zvýšilo pasivní tepelnou ochranu letounu. Výkony letounu, až na akceleraci a počáteční stoupavost zůstaly prakticky stejné. Zvětšila se ale nosnost výzbroje, dolet a výdrž v bojové oblasti. Celkem bylo přestavěno 26 kusů. Ty dostaly nové jméno Sa'ar. Velmi brzy se zapojili do války Jom-Kippur, hlavně útoky proti pozemním cílům. V roce 1975 přešla 105. tajeset na nové F-4 Phantom a Sa'ary byly vyřazeny. Dva kusy zůstaly v Izraeli jako muzejní, zbylých 18 kusů koupil Honduras. Před dodání prošly Sa'ary generální opravou, při které byla do letounů zabudována modernější vystřelovací sedačka. Honduras používal Sa'ary až do devadesátých let minulého století. Dopříchodu F-5 Tiger představovaly páteř protivzdušné obrany. Na kontě honduraských Sa'arů je několik sestřelů letounů drogových mafií a také nikaragujský vrtulník Mi 25.

rozpětí: 10,51 m, délka: 14,13 m, max. rychlost u hladiny moře/ ve výšce 12000 m: 1038 km / 1189 km (1,12 Mach), dolet s přídavnými nádržemi: 1790 km, dostup: 16 667 m.

PLASTIC PARTS

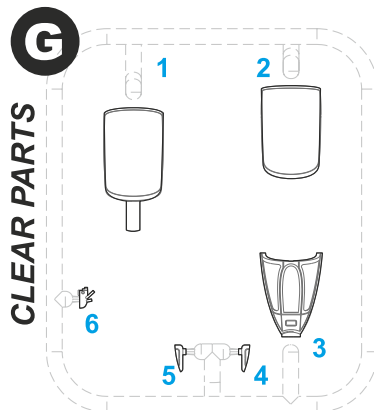
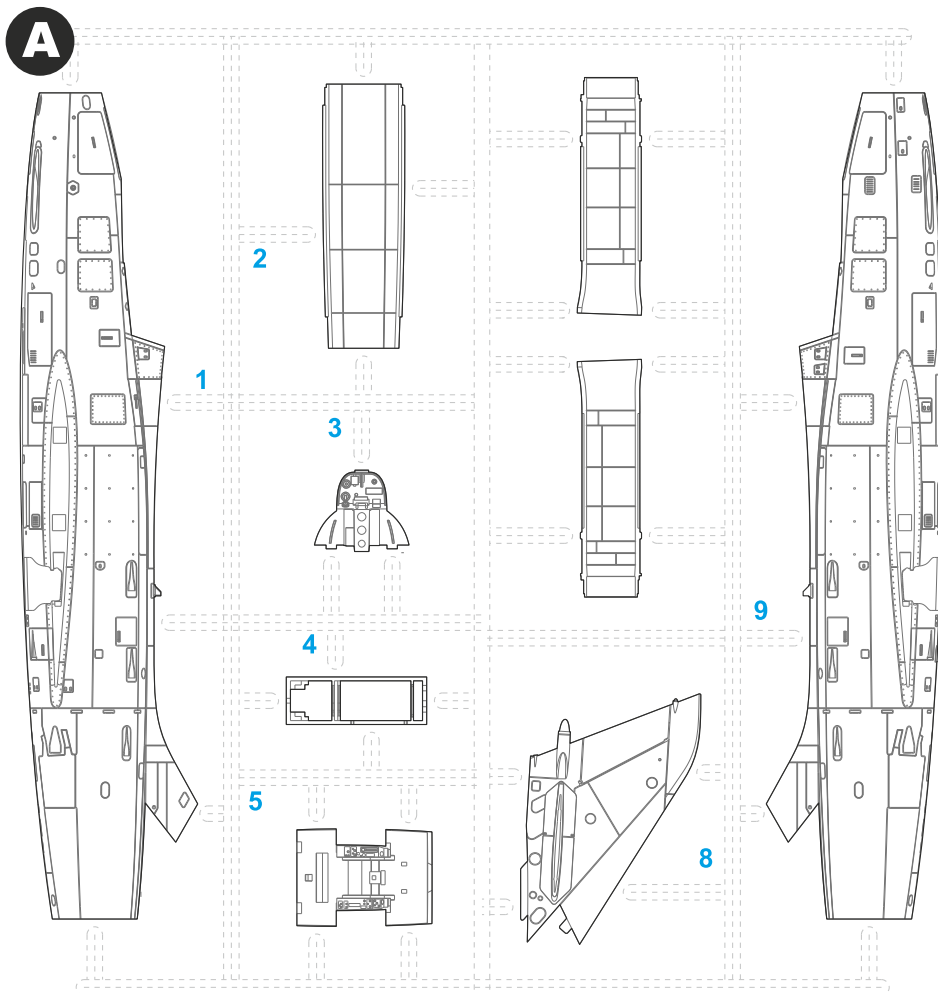

Barvy GUNZE/ GUNZE Colour No.

A	Černá / Black	H12/C33
B	Bílá / White	H11/C62
C	Hliníková / Aluminium	H/C8
D	Matná hliníková / Dull Alumin.	H8+11/C8+62
E	Opálený kov / Burnt Iron	H76/C61
F	Chromová / Chrome Silver	MC211
G	Žlutá / Yellow	H/C4
H	Krémově žlutá / Cream Yellow	H34
I	Červená / Red	H/C3
J	Červená čirá / Clear Red	H90/C47
K	Zelená čirá / Clear Green	H94/C138
L	Barva pneu / Tire Black	H77/C137
M	Letecká šedá / Aircraft Gray	H57/C73
N	Světle hnědá / Tan	H51/C44
O	Olivová / Olive Drab	H52/C12

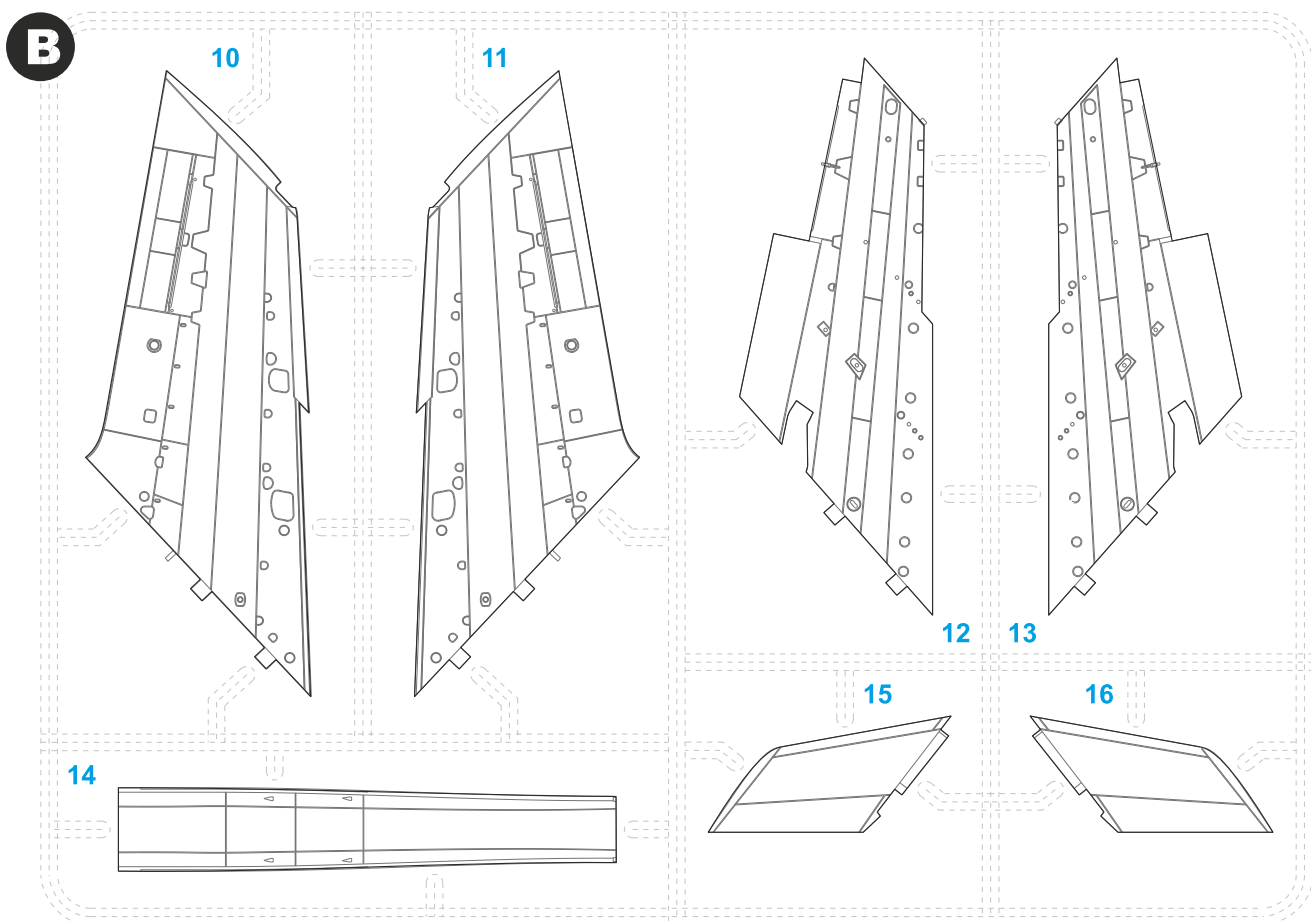

PLASTIC PARTS

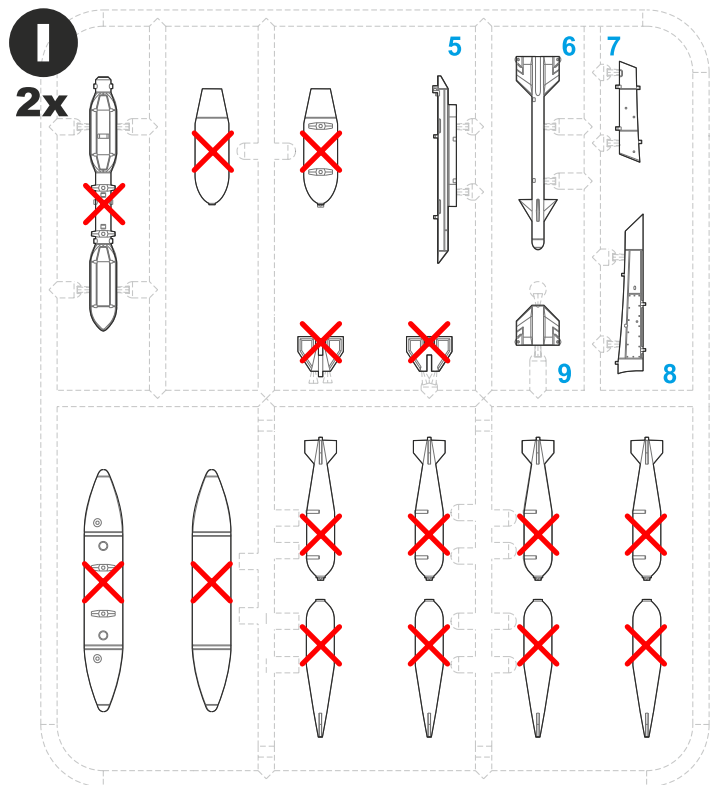
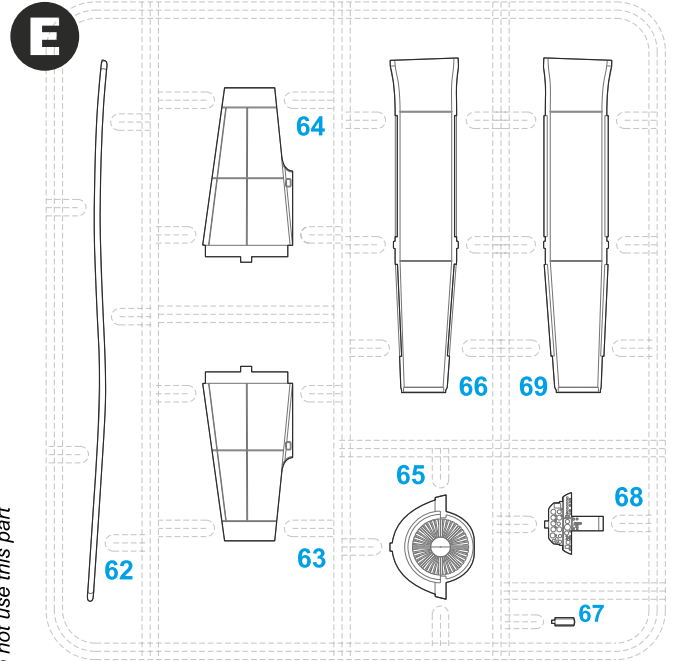
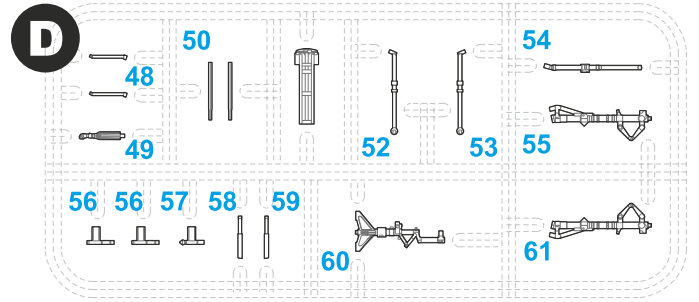
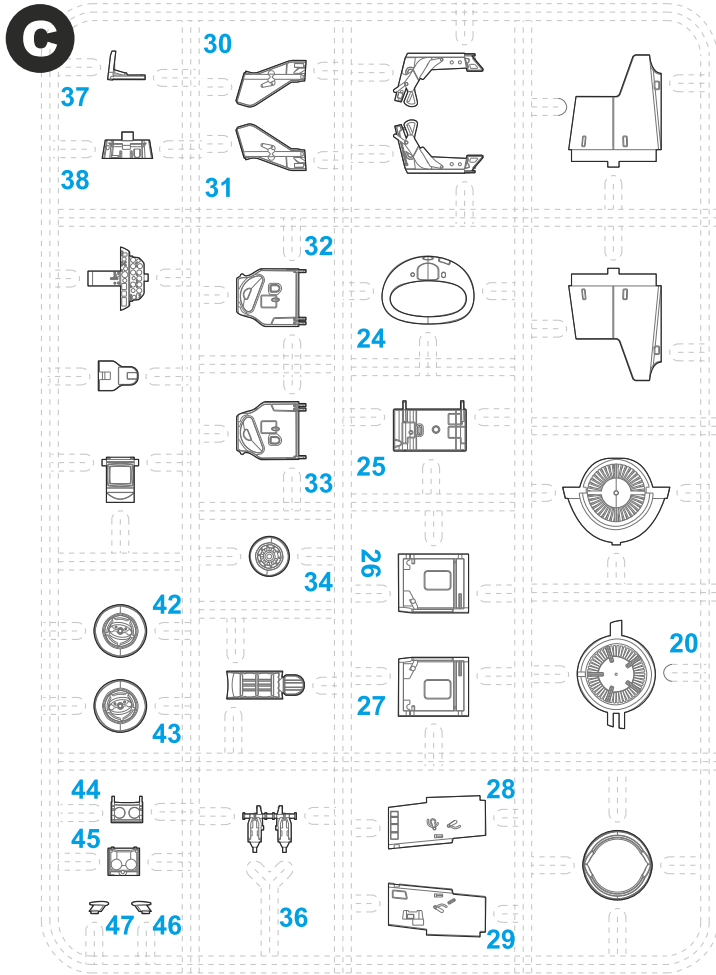

Tento díl nepoužít
Do not use this part



PUR parts

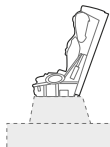

PUR 1



PUR 2 (2x)

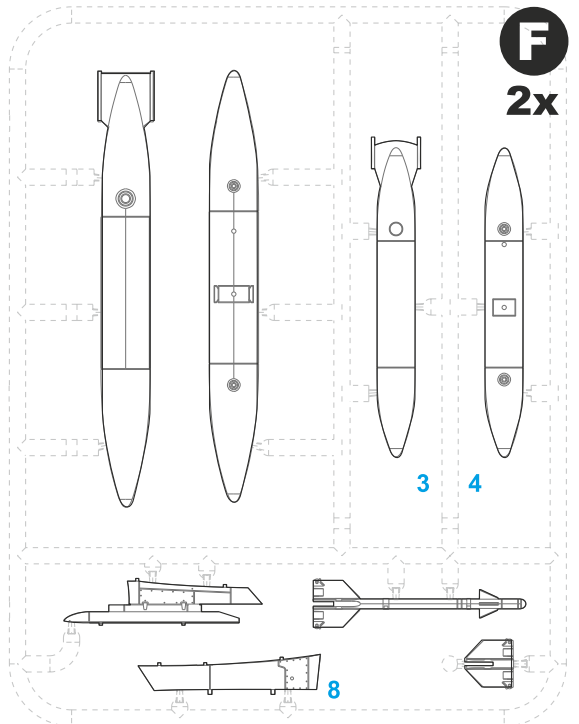

SYMBOLS



MOŽNOST VOLBY
OPTIONAL
NACH BELIEBEN
OPTION



POUŽÍT KYANOAKRYLÁTOVÉ LEPIDLO
INSTANT CYANOACRYLATE GLUE
ZYANOAKRYLATKLEBER
ADHÉSIF CYANOACRYLAT



OHNOUT
BEND
BIEGEN
COURBER



ZHOTOVIT NOVÉ
SCRATCH BUILD
FERTIGSTELLEN
ACHEVER



ŘEZAT/VRTAT
CUT OFF/DRILL
ENTFERNEN
DETACHER



NATRÍT
COLOUR
FARBEN
PEINDRE

NOTE:
Red Steps show the
 French schemes
 (A,B) build

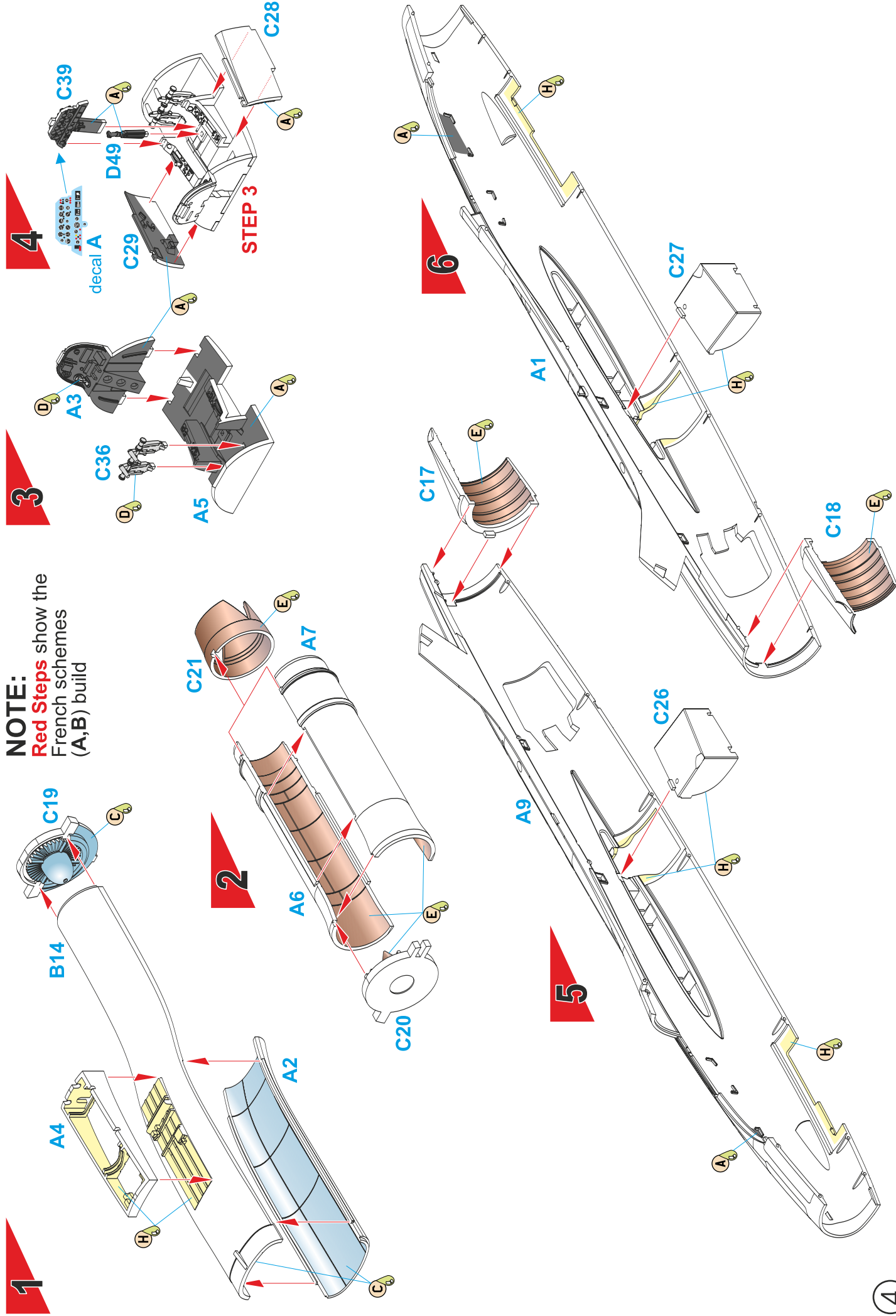

1

NOTE:
Blue Steps show the Honduran scheme (C) build

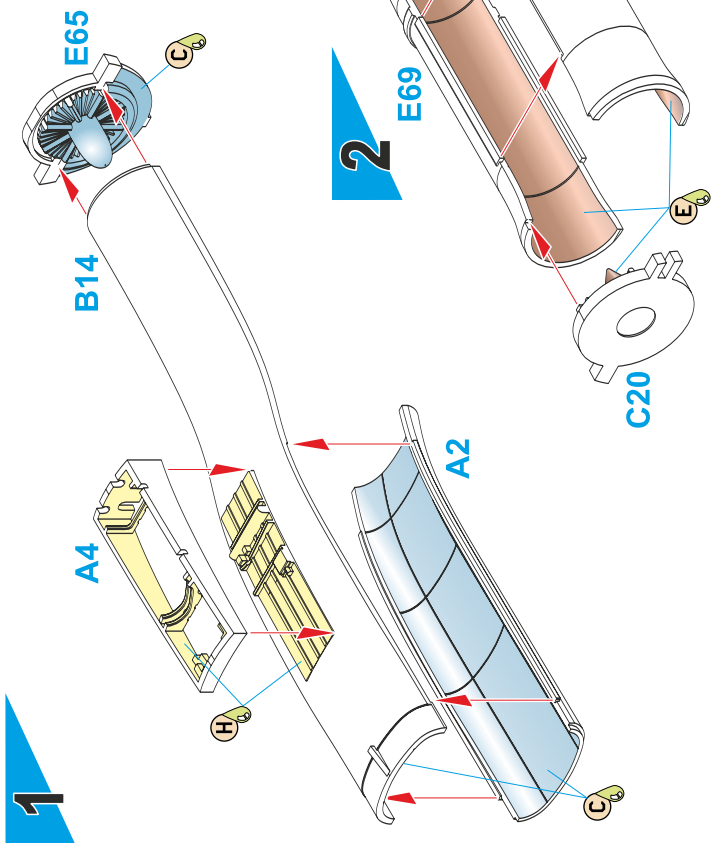

2

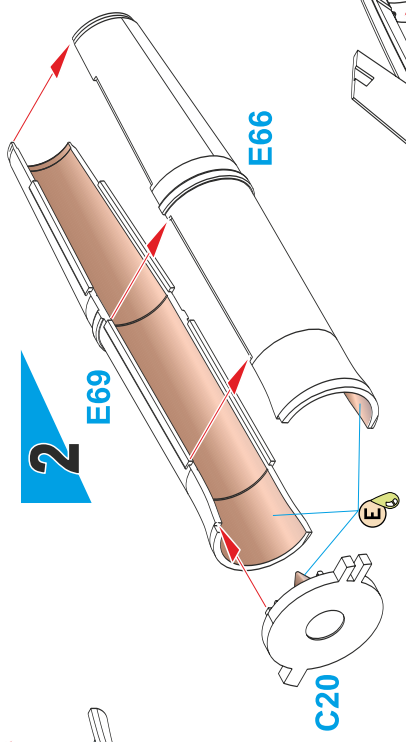

3

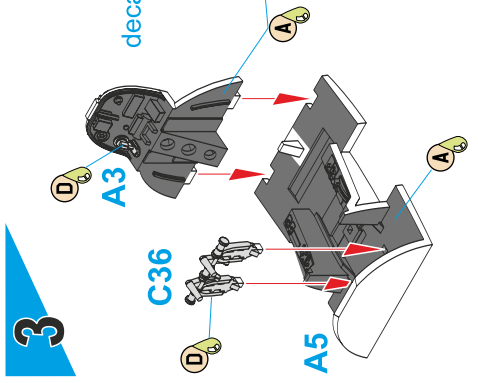

4

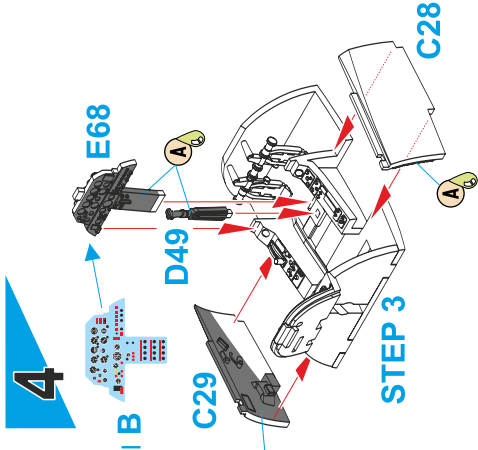

STEP 3

6

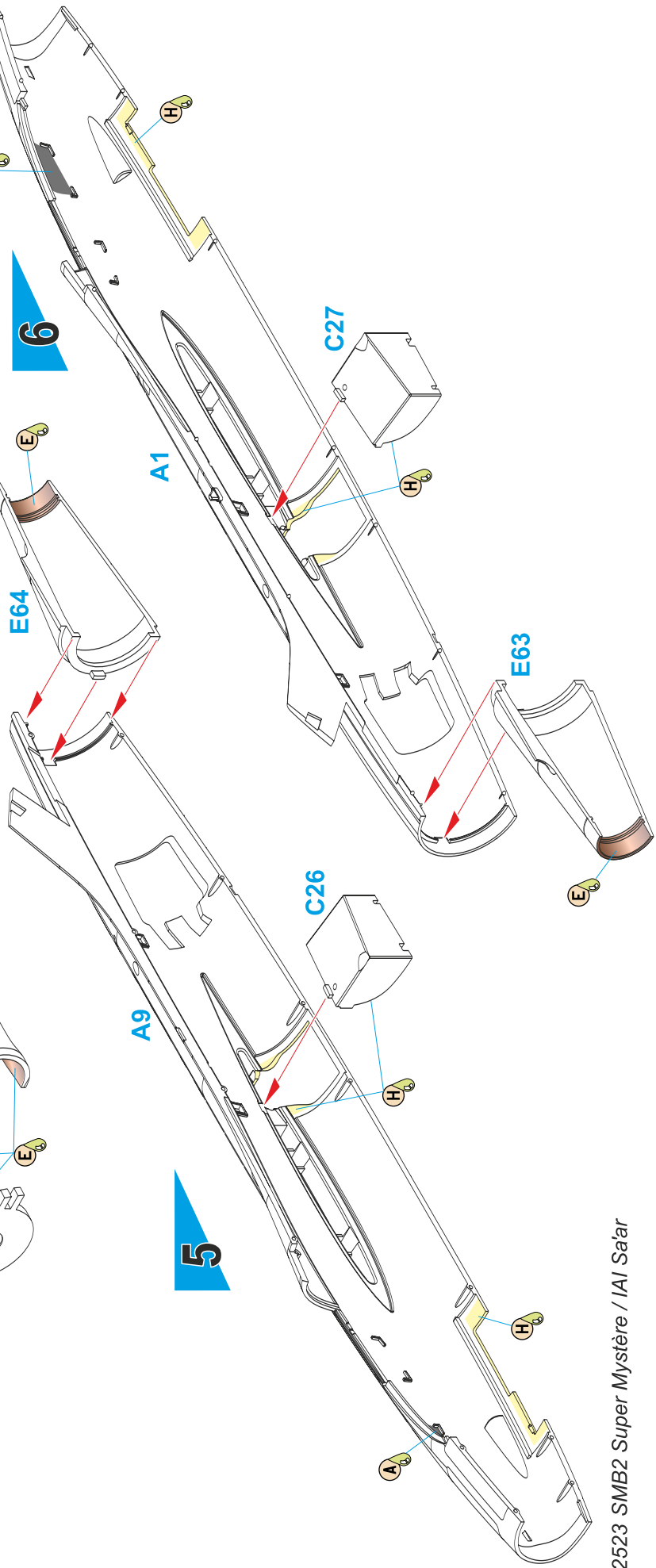

5

NOTE:
Red Steps show the
French schemes
(A,B) build

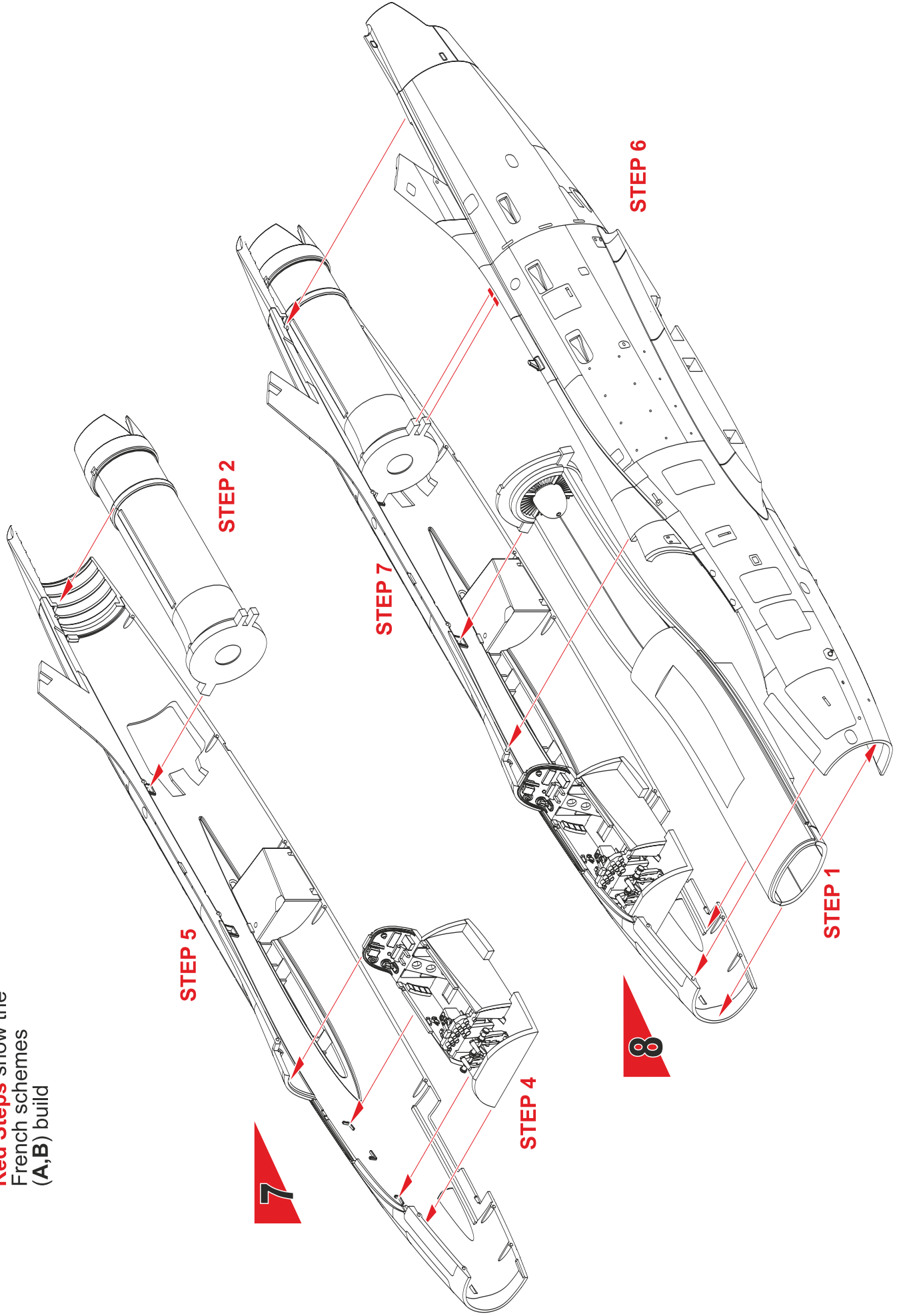

NOTE:
Blue Steps show the Honduran scheme (C) build

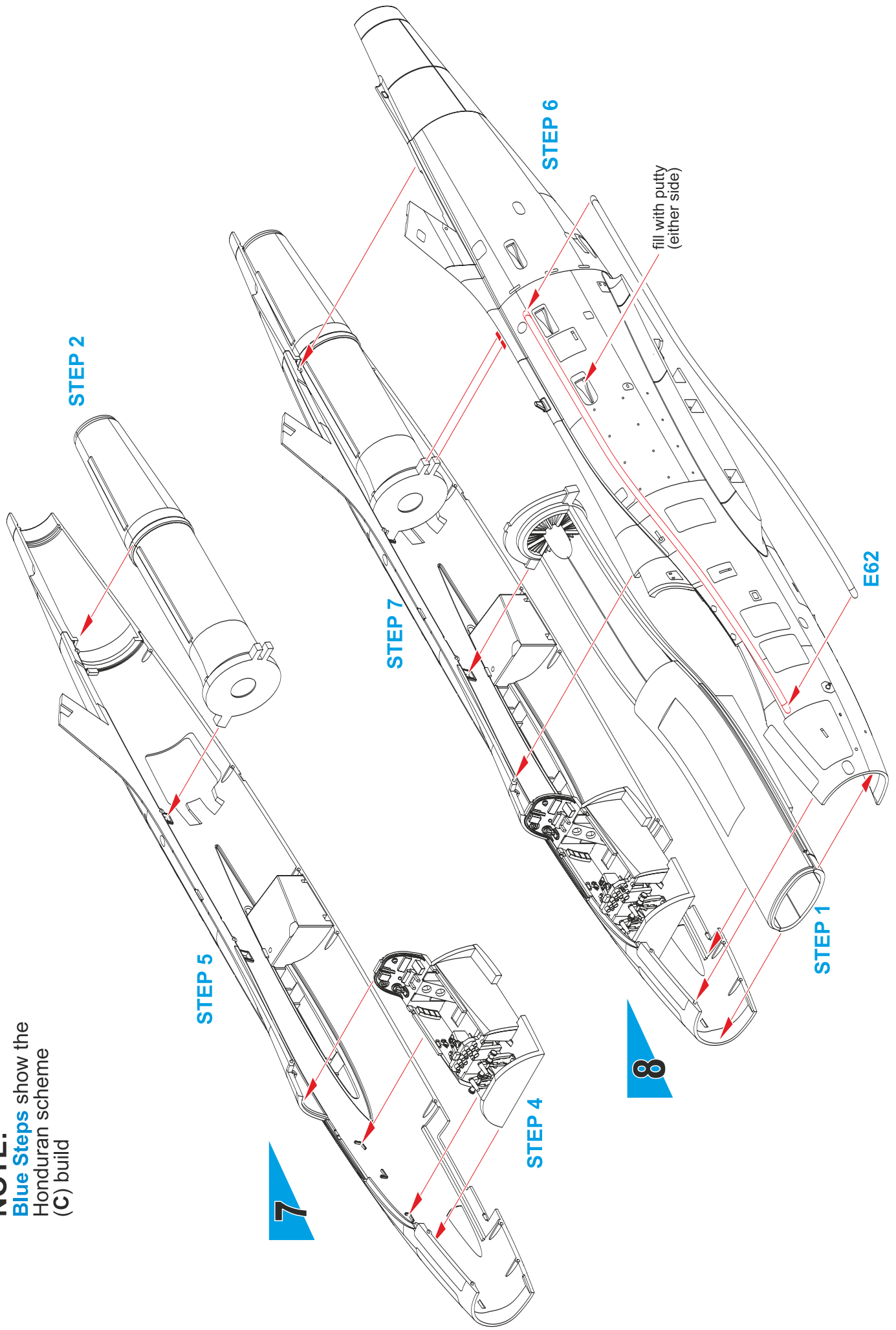

NOTE:
Orange Steps are common
for all schemes.

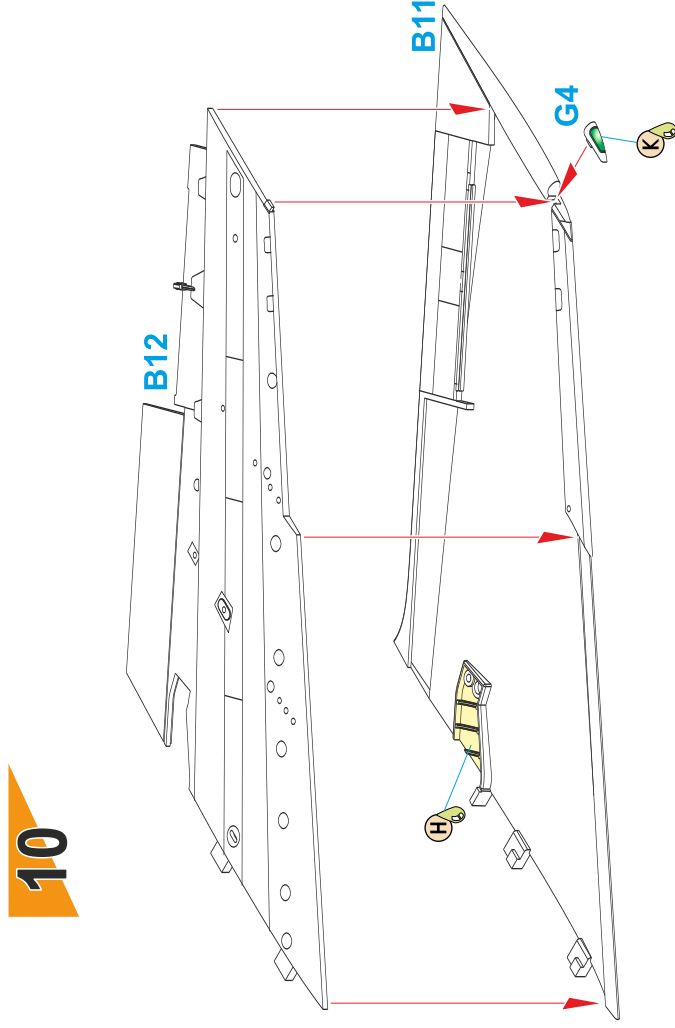
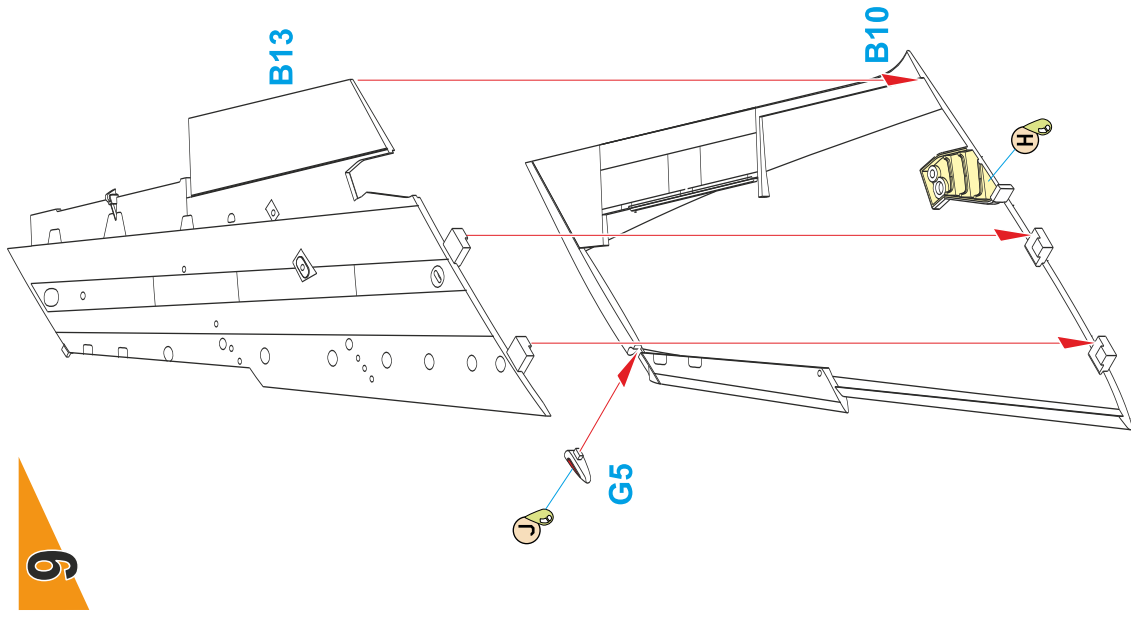

NOTE:
Orange Steps are common
for all schemes.

Scheme C



PUR2
symmetrical
assembly

check the correct position
with the colour schemes

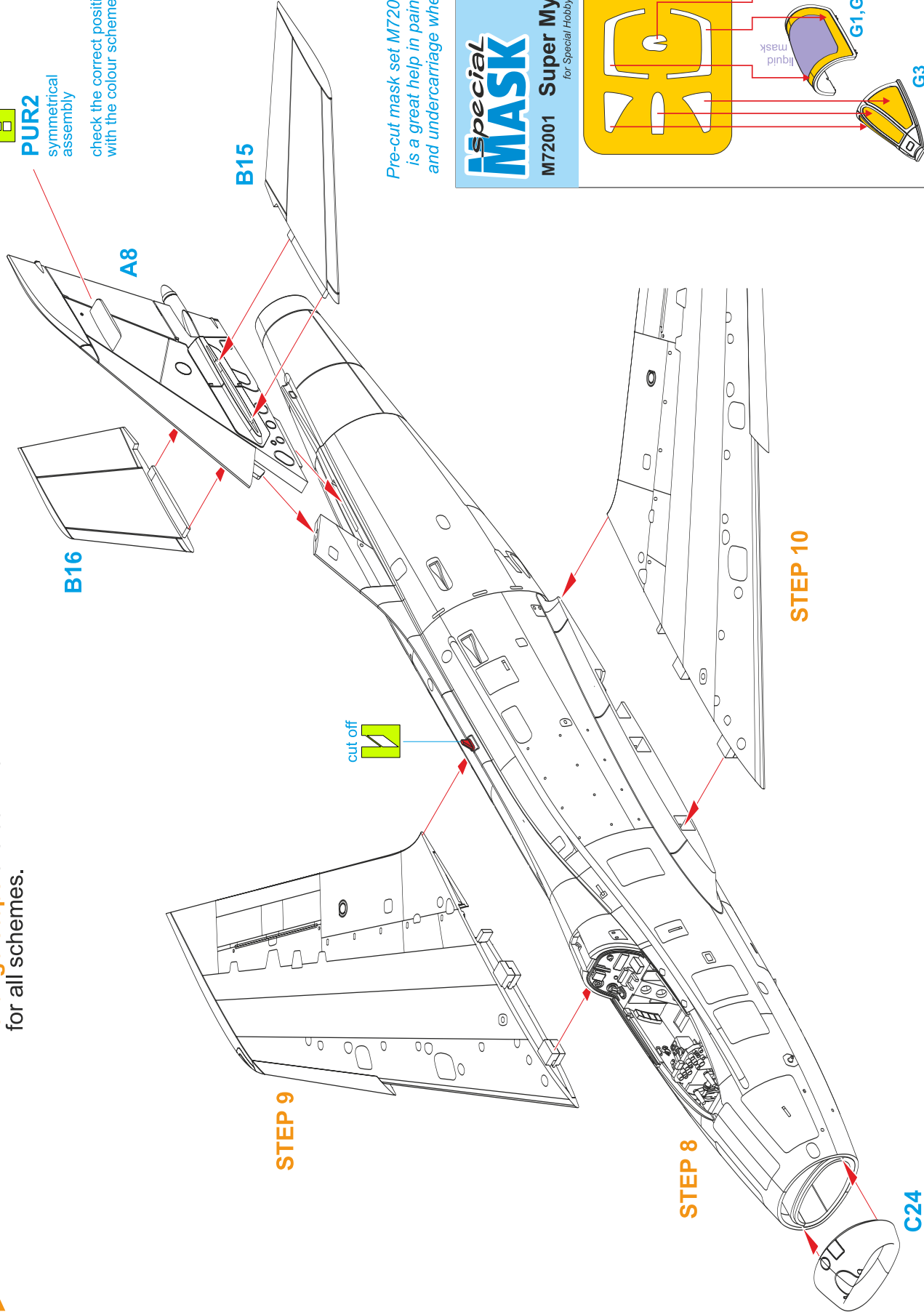

Pre-cut mask set M72001 (available separately)
is a great help in painting the canopy frames
and undercarriage wheel tyres. Get yours, too!

Special MASK
M72001 Super Mystère SMB.2 1/72
for Special Hobby and Azur/From kits

NOTE:
Orange Steps are common
 for all schemes.

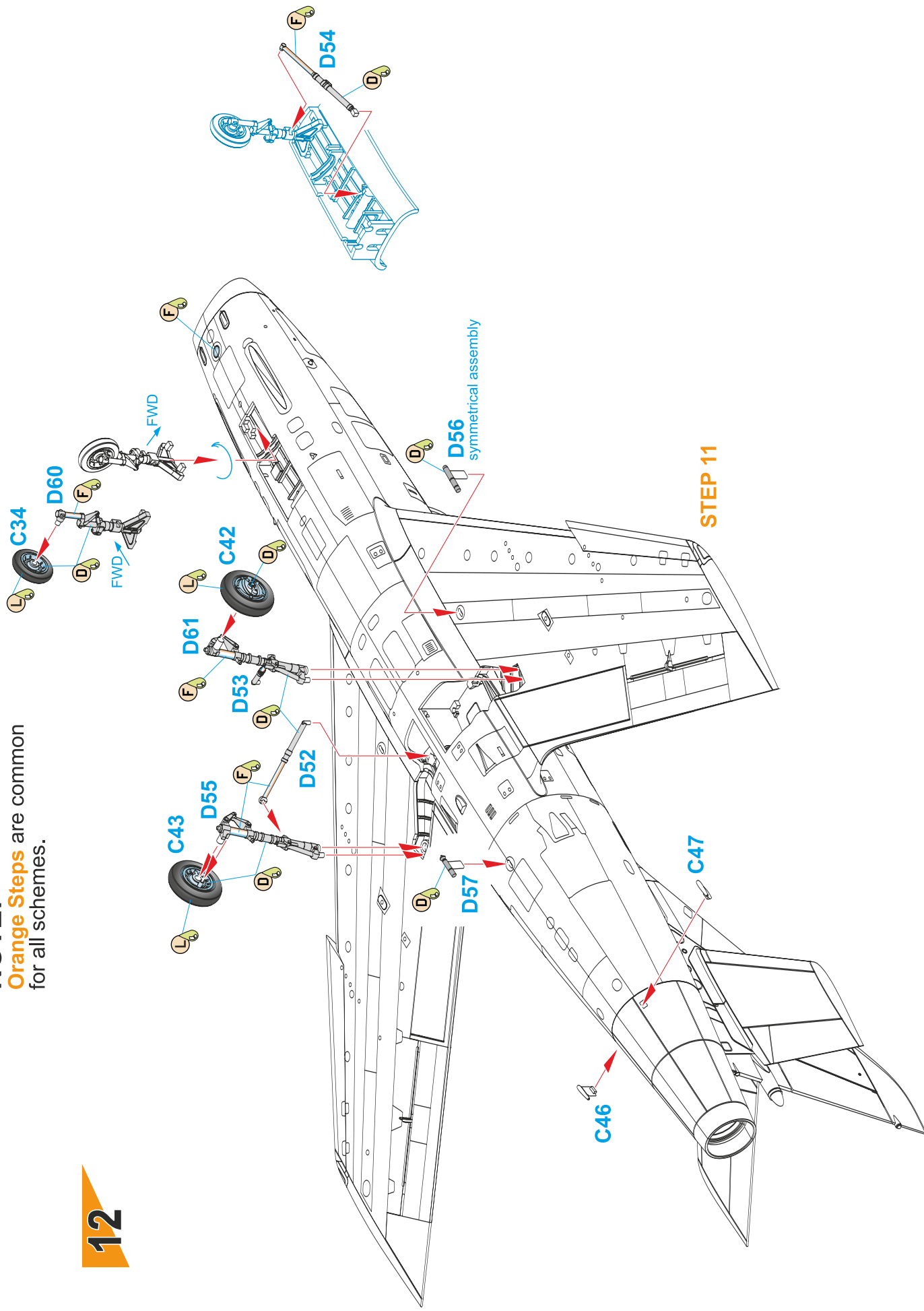

13

Note:
Undercarriage doors C25,32,33
were usually left closed
while on the ground.

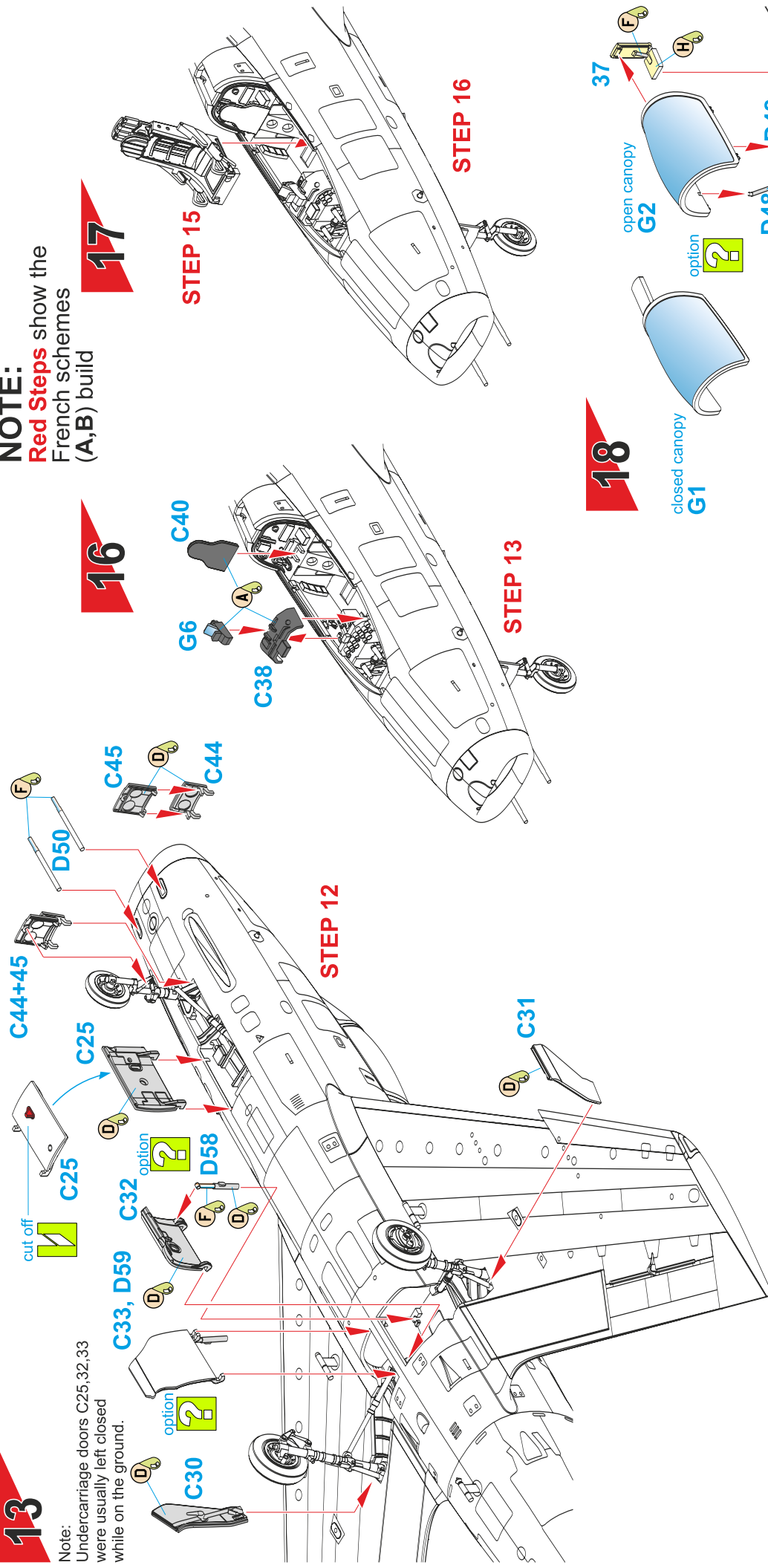

16

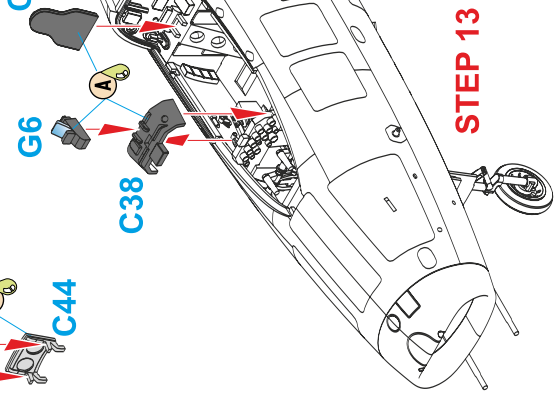

STEP 16

STEP 15

17

NOTE:
Red Steps show the
French schemes
(A,B) build

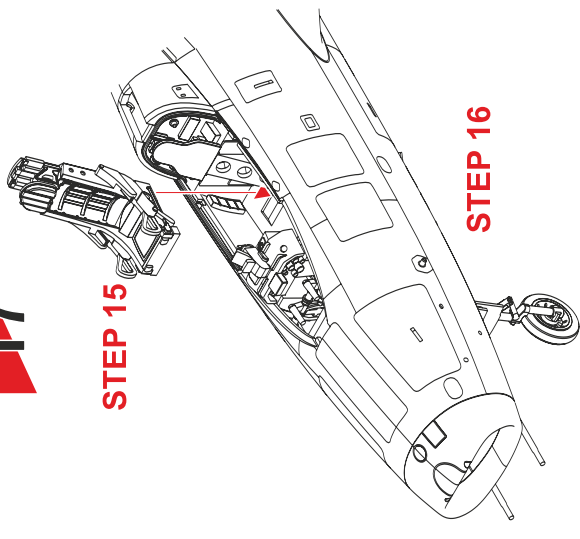

18

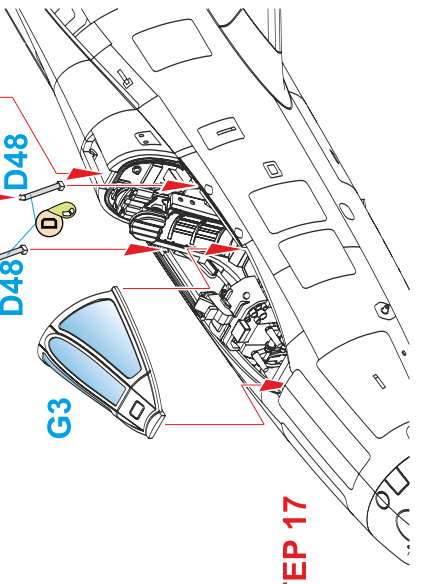

STEP 17

15

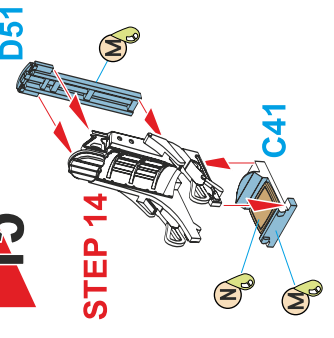

STEP 14

14

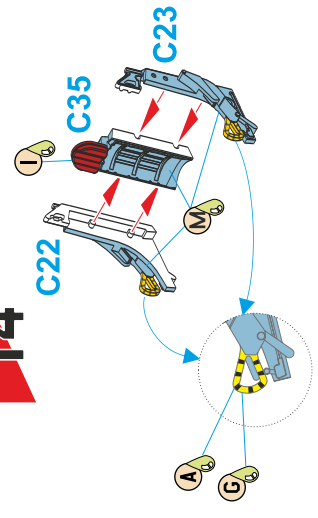

13

Note:
Undercarriage doors C25,32,33
were usually left closed
while on the ground

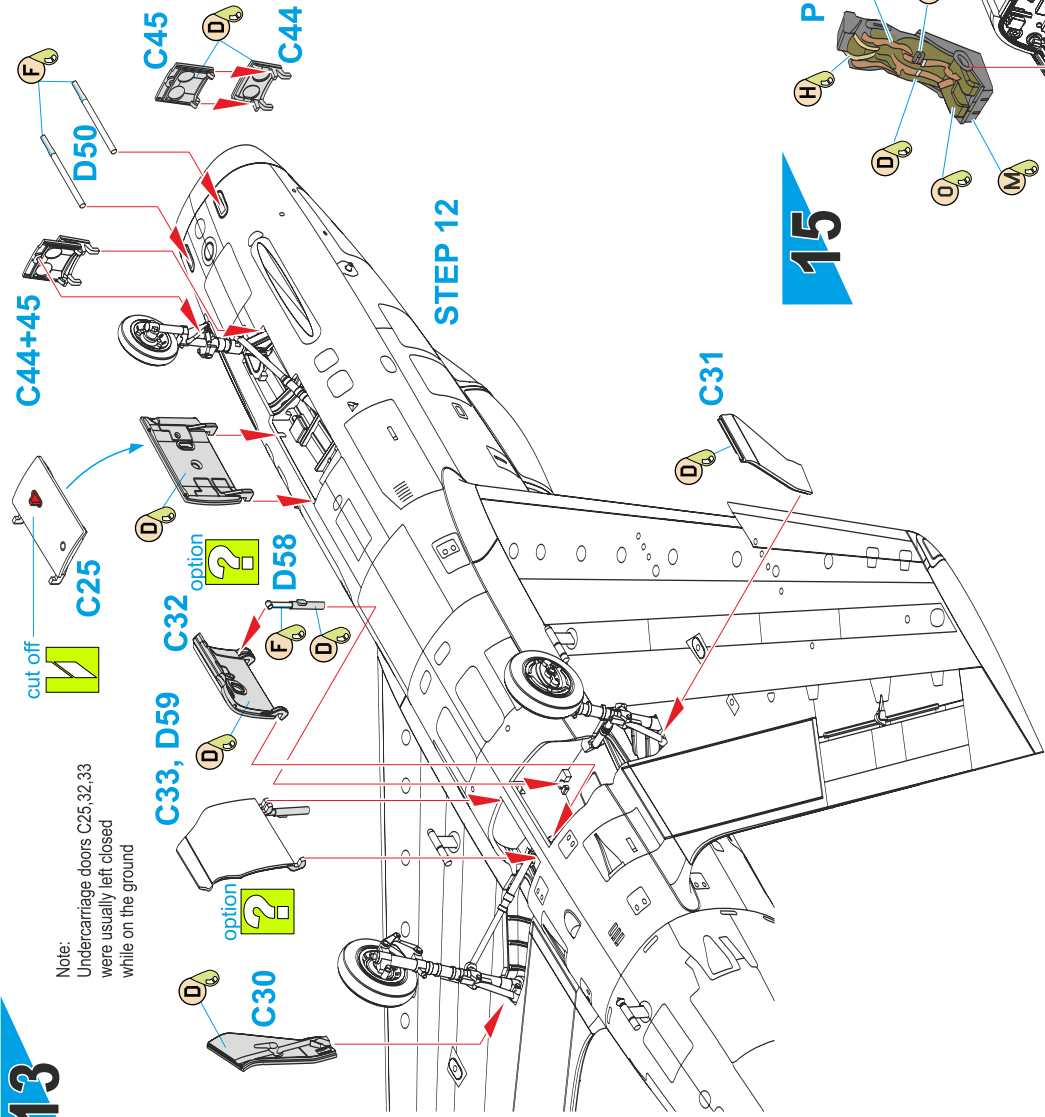

STEP 12

14

NOTE:
Blue Steps show the
Honduran scheme
(C) build

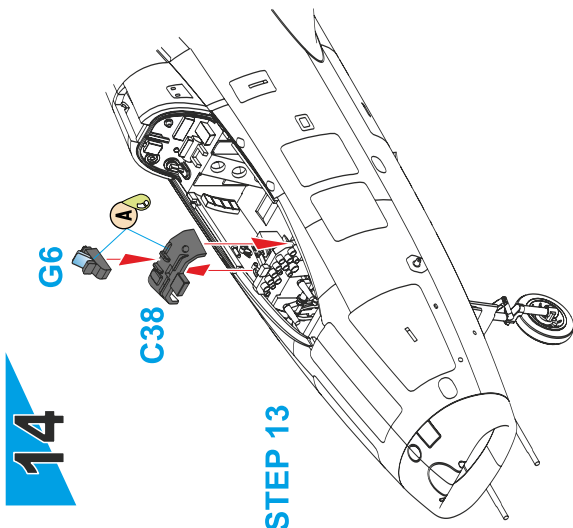

STEP 13

15

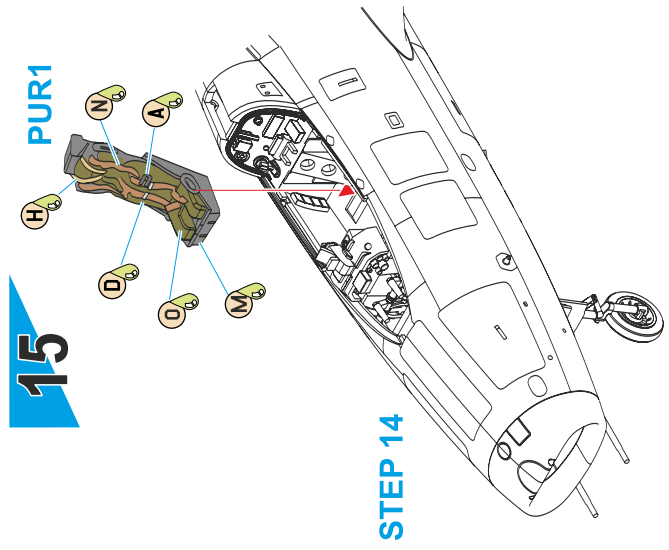

STEP 14

16

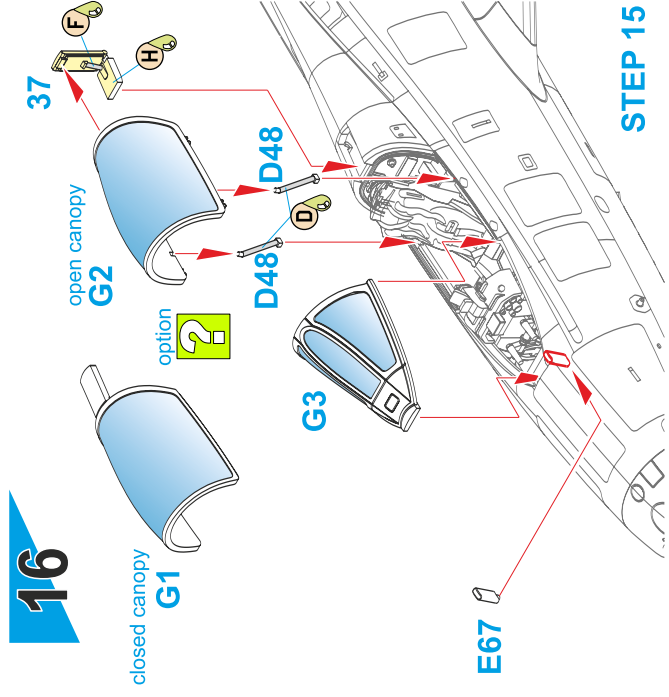

NOTE:
Orange Steps are common for all schemes.

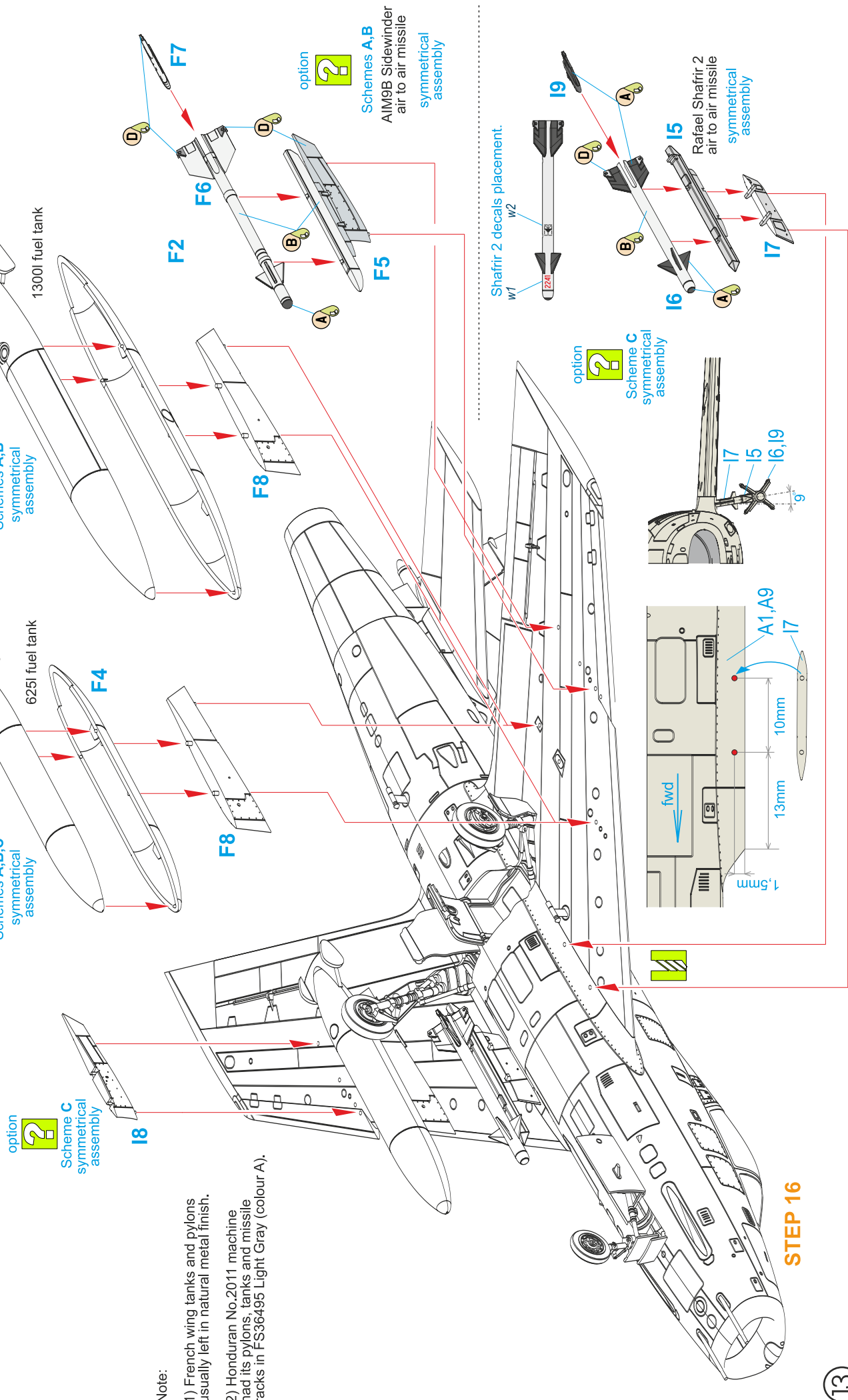

SMB.2 Super Mystère, 10-RD, c/n 67, 10^o escadre de chasse, escadron de chasse 02/010 'Seine', at Base Aérienne BA110 Creil, Armée de l'Air - French Air Force, May 1961 - September 1968.

SMB.2 Super Mystère, 10-RD, výr.č. 67, 10^o escadre de chasse, escadron de chasse 02/010 'Seine', základna BA110 Creil, Armée de l'Air - francouzské letectvo, květen 1961 - září 1968.

Scheme A

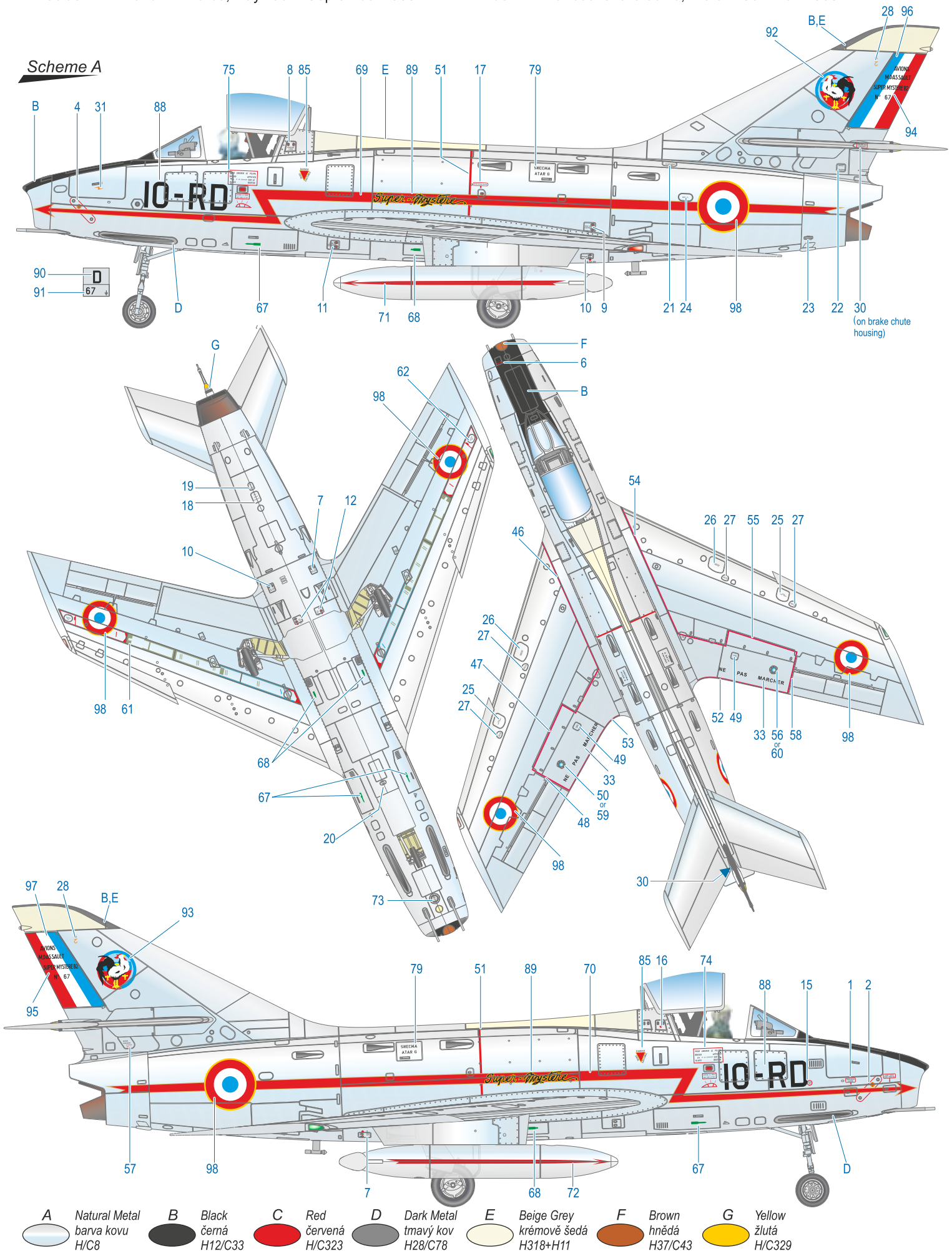

- | | | | | | | |
|--|------------------------------------|-----------------------------------|---|---|------------------------------------|------------------------------------|
| A Natural Metal
barva kovu
H/C8 | B Black
černá
H12/C33 | C Red
červená
H/C323 | D Dark Metal
tmavý kov
H28/C78 | E Beige Grey
krémové šedá
H318+H11 | F Brown
hnědá
H37/C43 | G Yellow
žlutá
H/C329 |
|--|------------------------------------|-----------------------------------|---|---|------------------------------------|------------------------------------|

SMB.2 Super Mystère, 5-OI, c/n 75, 5^e escadre de chasse, escadron de chasse 02/005 'Ile de France', at Base Aérienne BA115 Orange-Caritat, Armée de l'Air - French Air Force, June 1963 - August 1966.

SMB.2 Super Mystère, 5-OI, výr.č. 75, 5^e escadre de chasse, escadron de chasse 02/005 'Ile de France', základna BA115 Orange-Caritat, Armée de l'Air - francouzské letectvo, červen 1963 - srpen 1966.

Scheme B

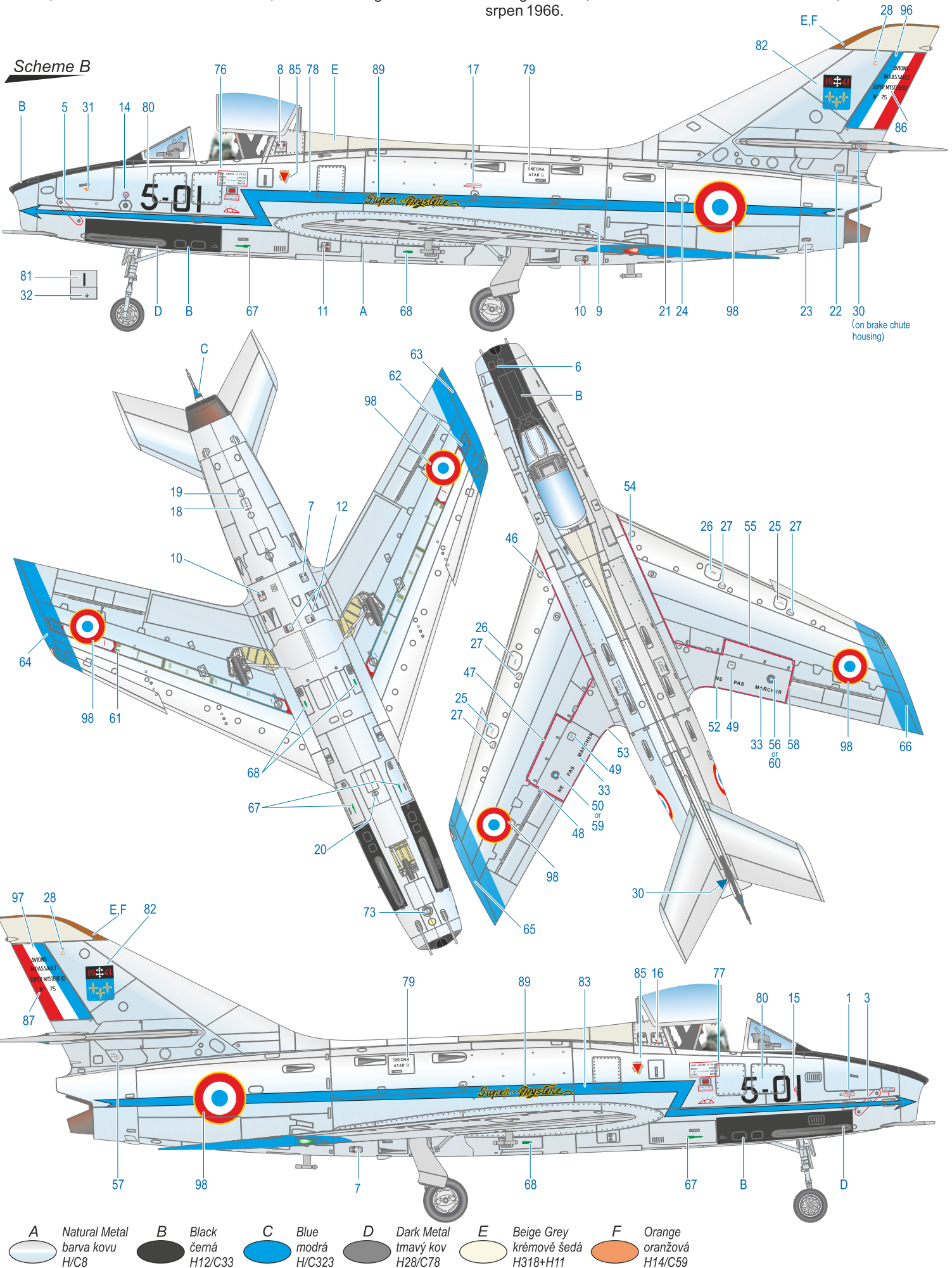

- | | | | | | |
|--|------------------------------------|----------------------------------|---|---|--|
| A Natural Metal
barva kovu
H/C8 | B Black
černá
H12/C33 | C Blue
modrá
H/C323 | D Dark Metal
tmavý kov
H28/C78 | E Beige Grey
krémové šedá
H318+H11 | F Orange
oranžová
H14/C59 |
|--|------------------------------------|----------------------------------|---|---|--|

IAI Sa'ar, no.2011, Fuerza Aérea Hondureña - Honduran Air Force, at La Ceiba, mid 1980s - late 1990s. At first, Honduran Sa'ars wore South East Asia camouflage scheme of two greens and tan on upper surfaces. After major repairs in the US in the mid '80s, the airframes were repainted in air superiority greys as depicted below.

IAI Sa'ar, no.2011, Fuerza Aérea Hondureña - honduraské letectvo, základna La Ceiba, polovina 80.let - konec let 90. Honduraské Sa'ary zpočátku nesly trojbarevné "South East Asia" schéma dvou zelených a střední hnědé. V polovině 80.let prošly stroje rozsáhlými opravami v USA a poté byly opatřeny novým schématem pro vzdušnou převahu sestávajícím ze tří světle šedivých odstínů.

Scheme C

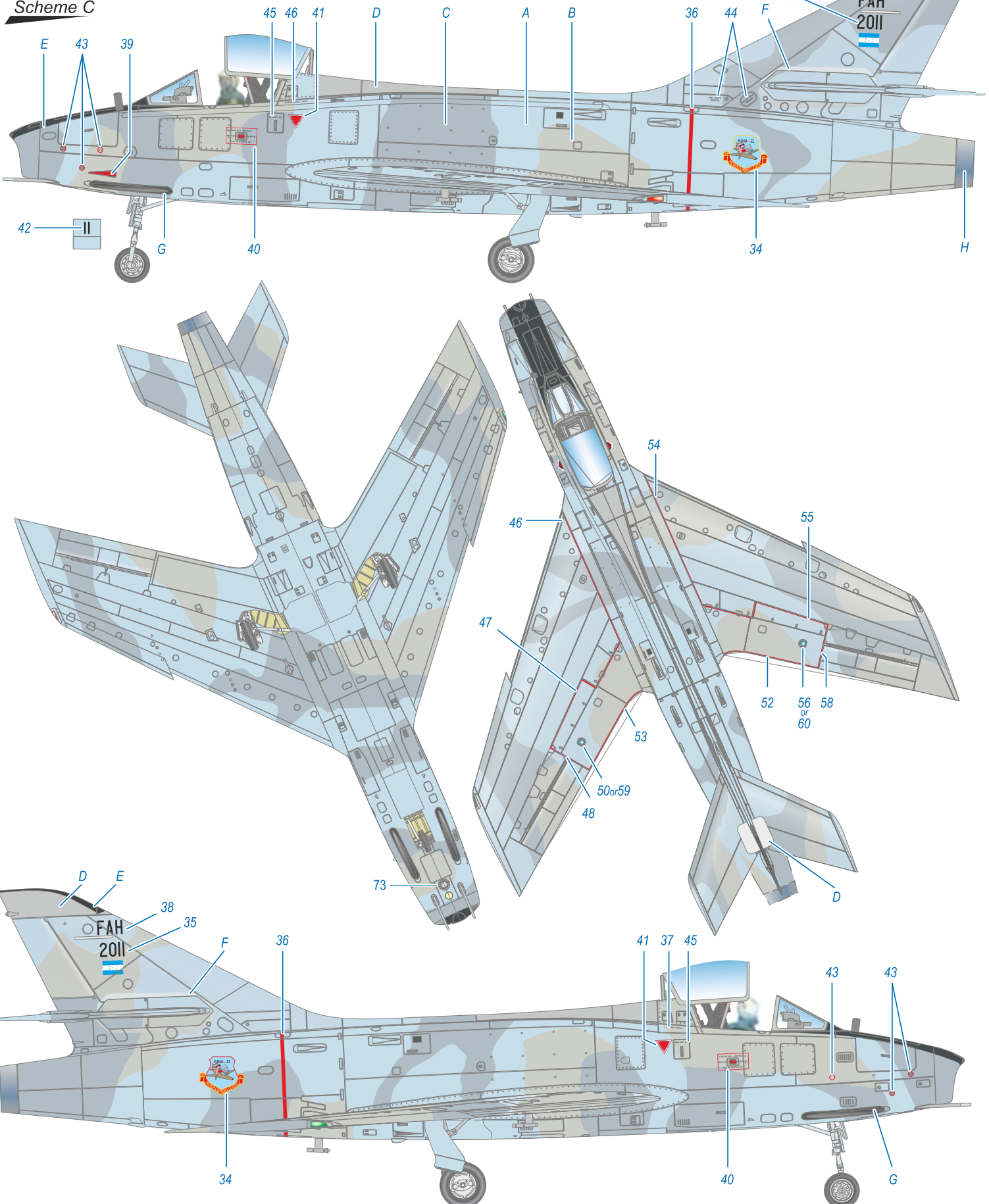

- | | | | | | | | |
|---|--|--|---|------------------------------------|--------------------------------------|---|--|
| A Light Gray
sv.šedá
FS36495
H/C338 | B Gray
šedá
FS16622
H/C311 | C Bluish Gray
šedomodrá
FS16473
H/C338+H53/C13
<small>(50/50% note: approx.match)</small> | D Light Gray
sv.šedivá
H51/C11 | E Black
černá
H12/C33 | F hliník
Aluminium
H/C8 | G Dark Metal
tmavý kov
H28/C78 | H Burnt Metal
opálený kov
H76/C61 |
|---|--|--|---|------------------------------------|--------------------------------------|---|--|