

Clear Prop!

ADVANCED



DH.88 COMET

MacRobertson Trophy
Air Race

1:72

model # CP72051



scale model kit

SPAN 186.26mm

LENGTH: 122.8 mm

NUMBER OF PARTS: 105 pcs

- 1** stages of assembly
- ?** optional
- A** variants of assembly
- glue by super glue
- A1** part number
- do not glue
- fill with putty
- make a hole
- 1** apply decals
- detach with knife
- apply the adhesive mask
- paint
- bend
- repeat the operation N times

Role: Racing aircraft
 Manufacturer: de Havilland
 Designer: A. E. Hagg
 First flight: 8 September 1934
 Status: One airworthy; one in restoration
 Number built: 5

G-ACSR was the second of DH designer Arthur Hagg's 'plywood bullets' constructed for the 1934 England-Australia race. It was paid for by Australian racing driver Bernard Rubin, winner of the 1928 Le Mans race (with Woolf Barnato) and one of the famed 'Bentley Boys', which made the colour scheme chosen for his new aircraft an obvious choice. Rubin had recently learned to fly and intended to participate in the race as co-pilot to his instructor, Ken Waller, Chief Flying Instructor of the Brooklands Flying Club, one of Britain's premier flying clubs of the 1930s. However, Rubin experienced a bout of illness and selected Owen Cathcart Jones to take his place. Former Fleet Air Arm pilot Cathcart Jones was a very experienced pilot and holder of a number of records, famously co-piloting another 'Bentley Boy', Glen Kidston's Lockheed Vega in his record-setting England-Capetown flight.

Take off from Mildenhall during the race was uneventful, but they experienced a number of technical issues en route (including a forced landing near Baghdad in the dark) and necessitating repairs at Baghdad and Batavia. These delays effectively put an end to challenging for the race win. They eventually reached Melbourne in 4th place, after an elapsed time of 108 hours 13 minutes. Having failed to win, they set about trying to set a record for the round trip England-Australia flight, which they accomplished in a total time of 13 days 6 hours and 43 minutes, bringing back some movie film of the race. This flight also was not without incident and they replaced some engine pistons with those from the Comet 'Black Magic', which was still stranded at Allahabad.

A few weeks after the race, it set some records flying to the Belgian Congo, flown by Ken Waller and Belgian Maurice Francomme. The following year, it was sold to France, where it was re-registered F-ANPY and set several French records flown by legendary pilot Jean Mermoz and was ultimately destroyed in 1940.

Roger Holden

REQUIRED PAINTS



MR. COLOR 90
A.MIG-8215
SHINE SILVER



MR. COLOR 383
A.MIG-0238
GREEN



MR. COLOR 8
A.MIG-0195
SILVER



MR. COLOR 1
A.MIG-0047
WHITE



MR. COLOR 33
A.MIG-0046
BLACK



MR. COLOR 44
A.MIG-0013
TAN



MR. COLOR 137
A.MIG-0033
TIRE BLACK



MR. COLOR 13
A.MIG-0239
NEUTRAL GREY



MR. COLOR 27
A.MIG-0220
INTERIOR GREEN



MR. COLOR 28
A.MIG-0191
STEEL



MR. COLOR 61
A.MIG-0187
BURNT IRON



AMMO
by MIG Jimenez

THIS MODEL IS PRODUCED FOR EXPERIENCED MODELERS OVER 14 YEARS

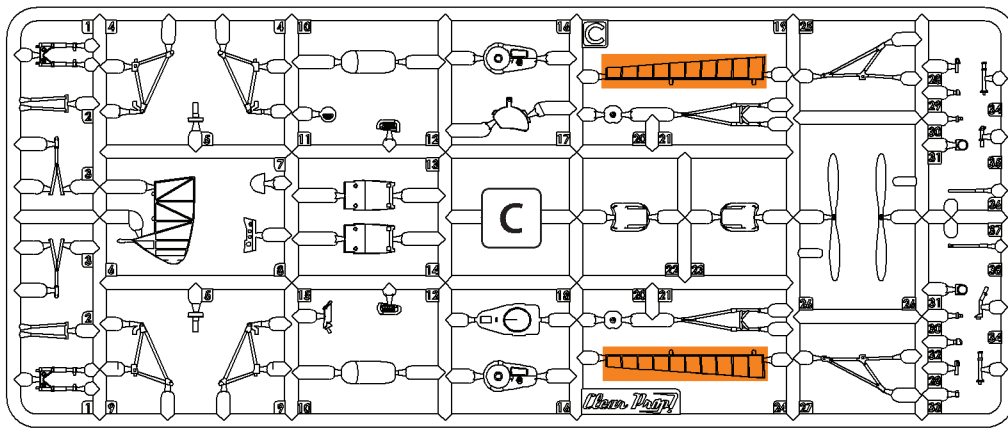
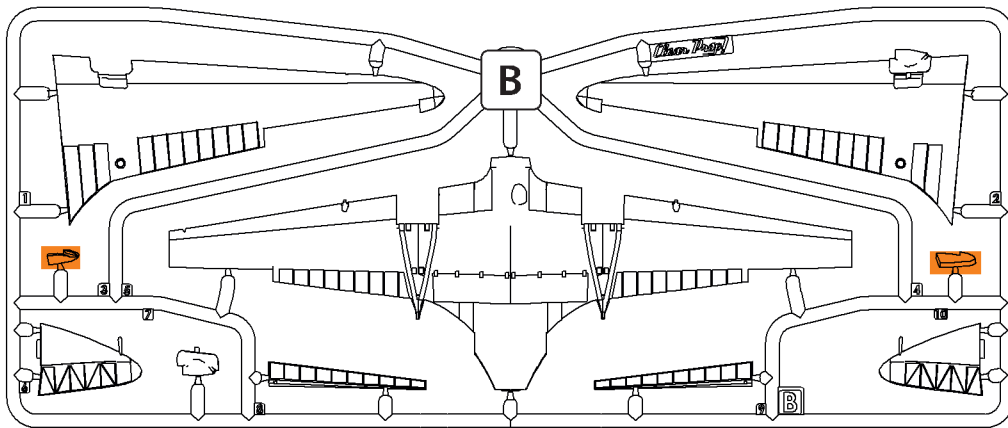
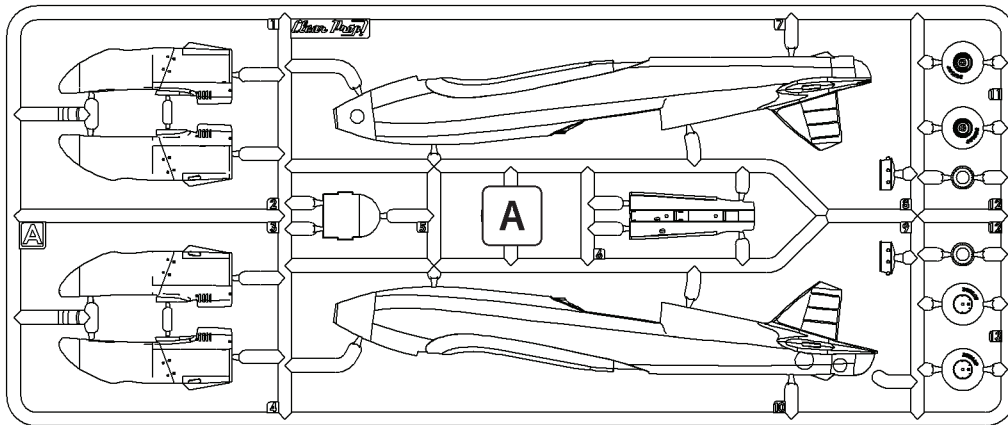

DECAL SHEET

PHOTOETCHED PARTS

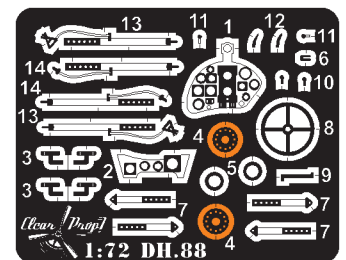
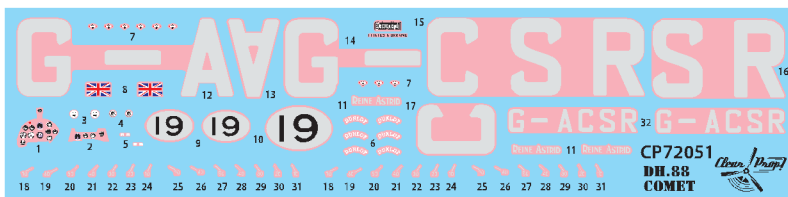
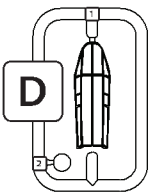

Parts not for use

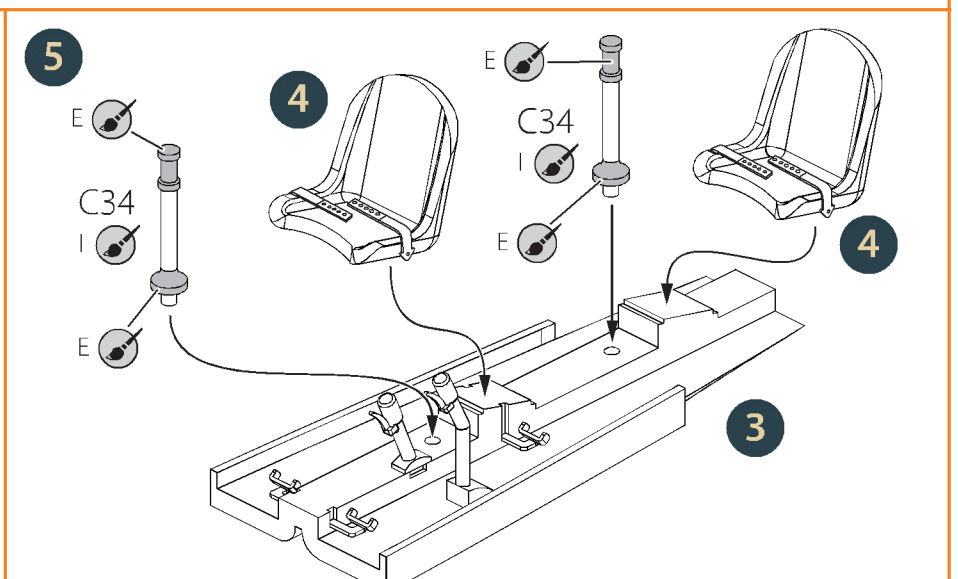
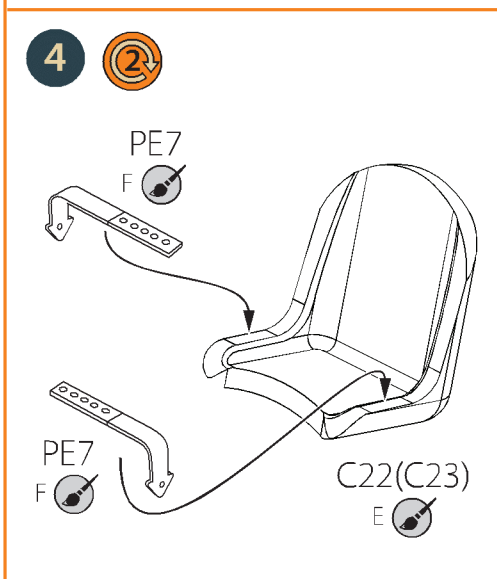
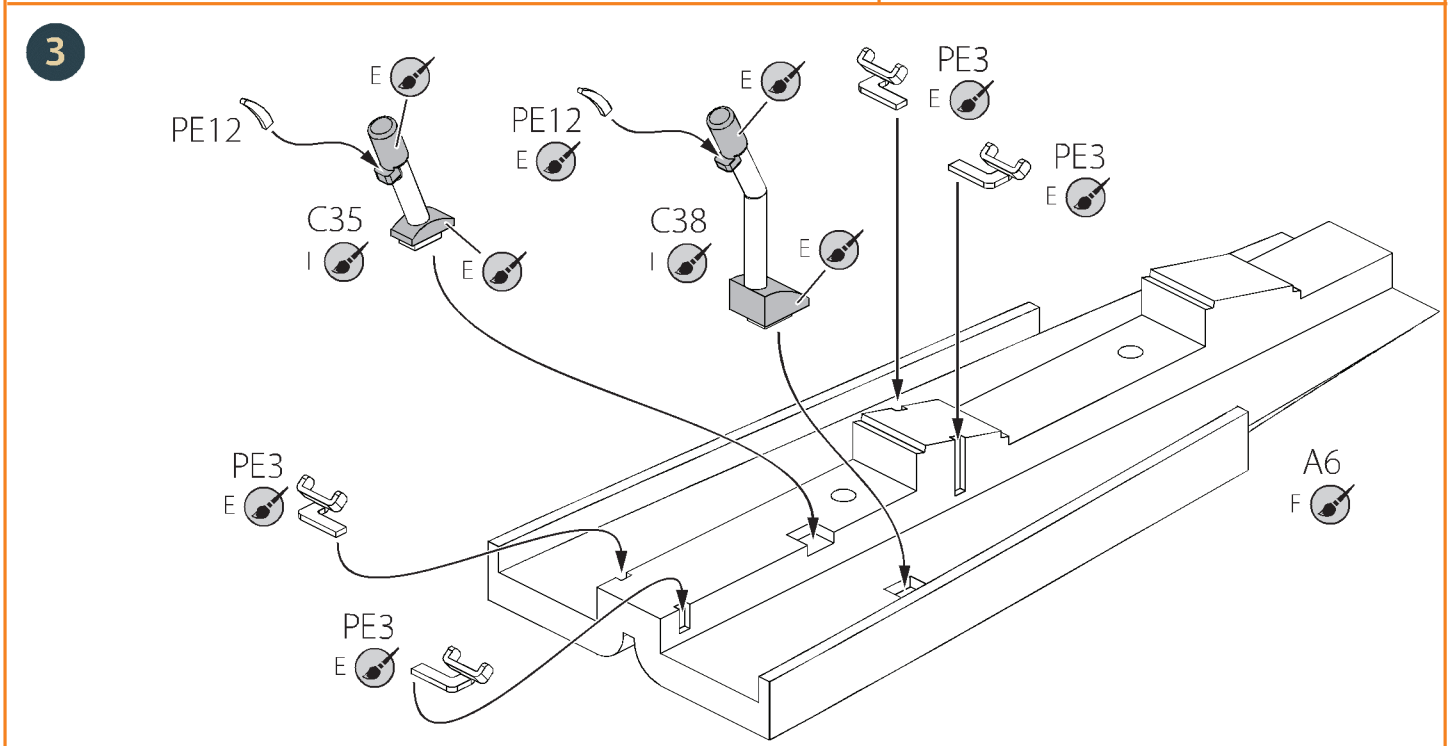
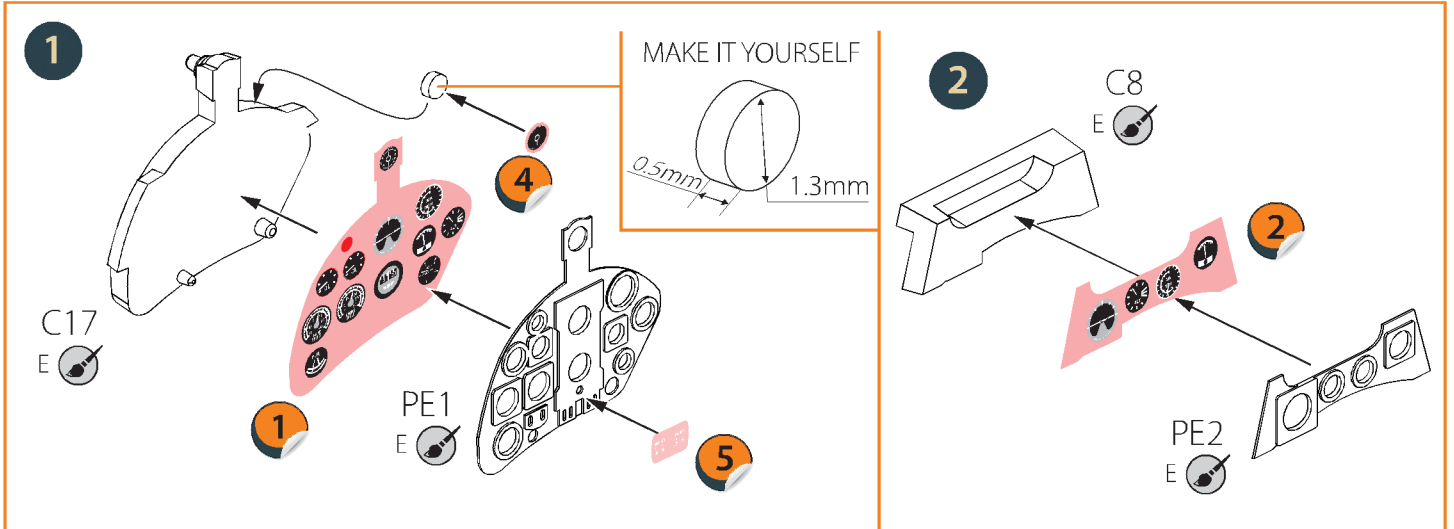

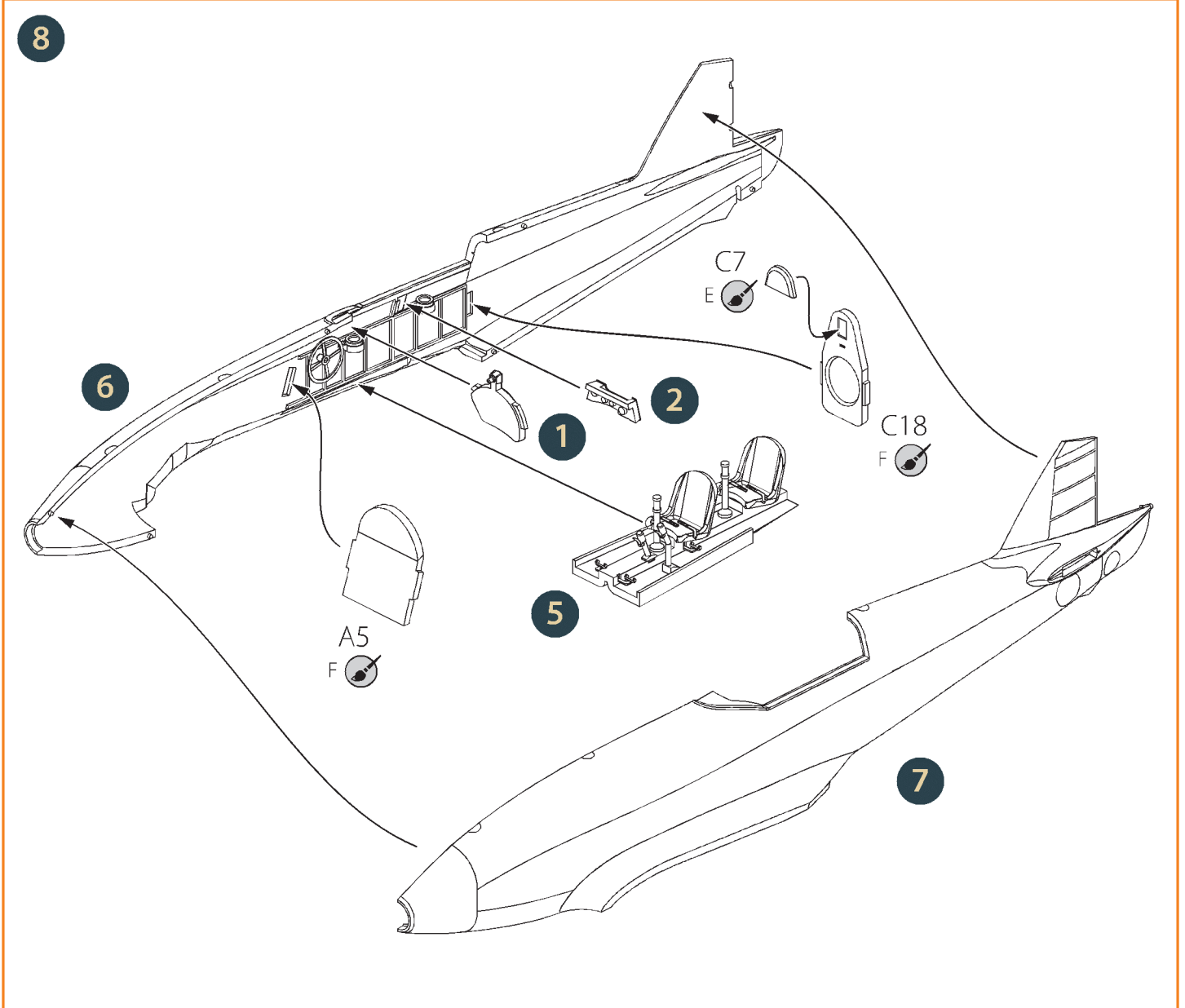
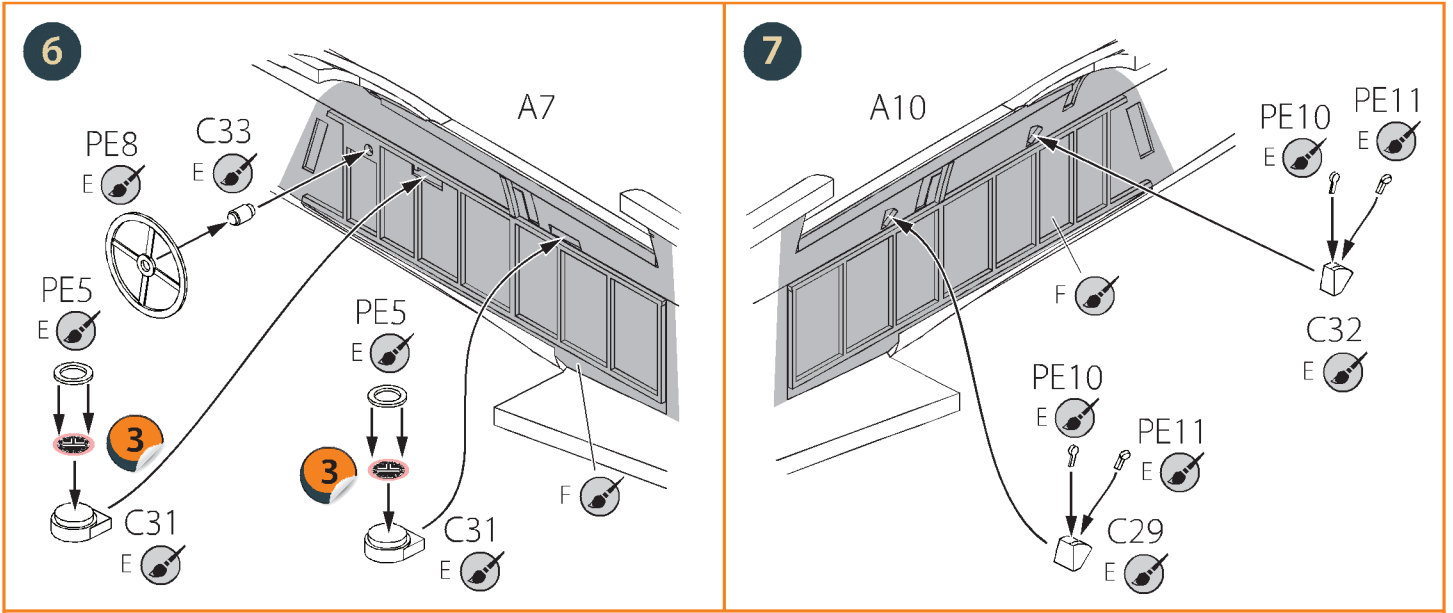

9

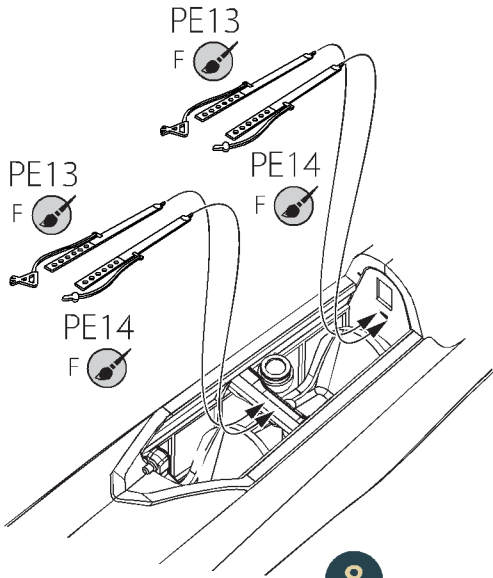

10

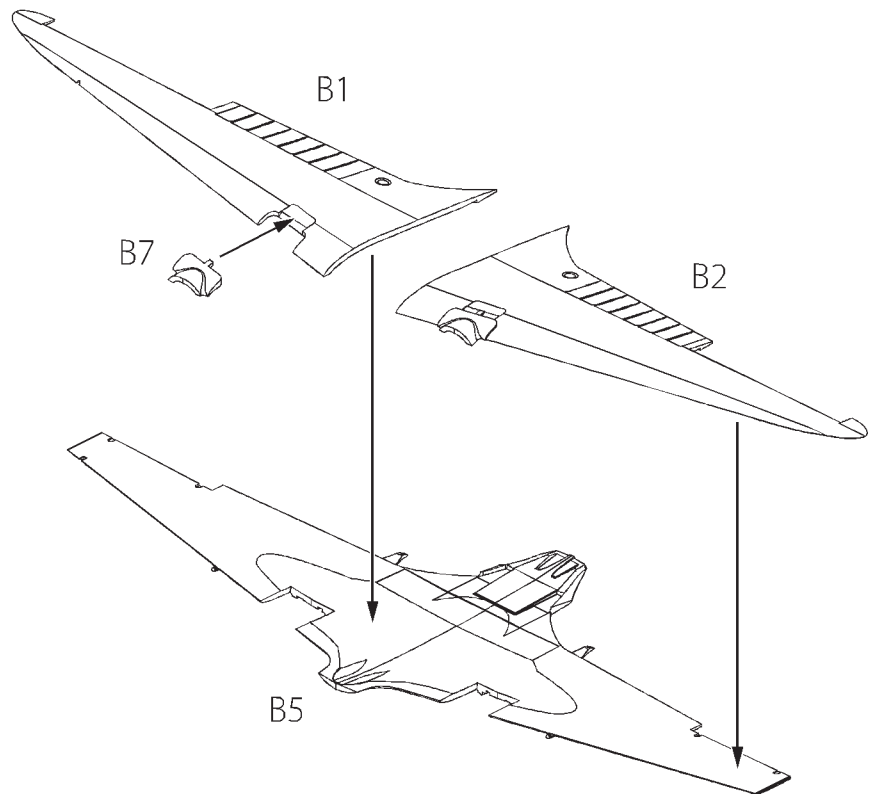

11

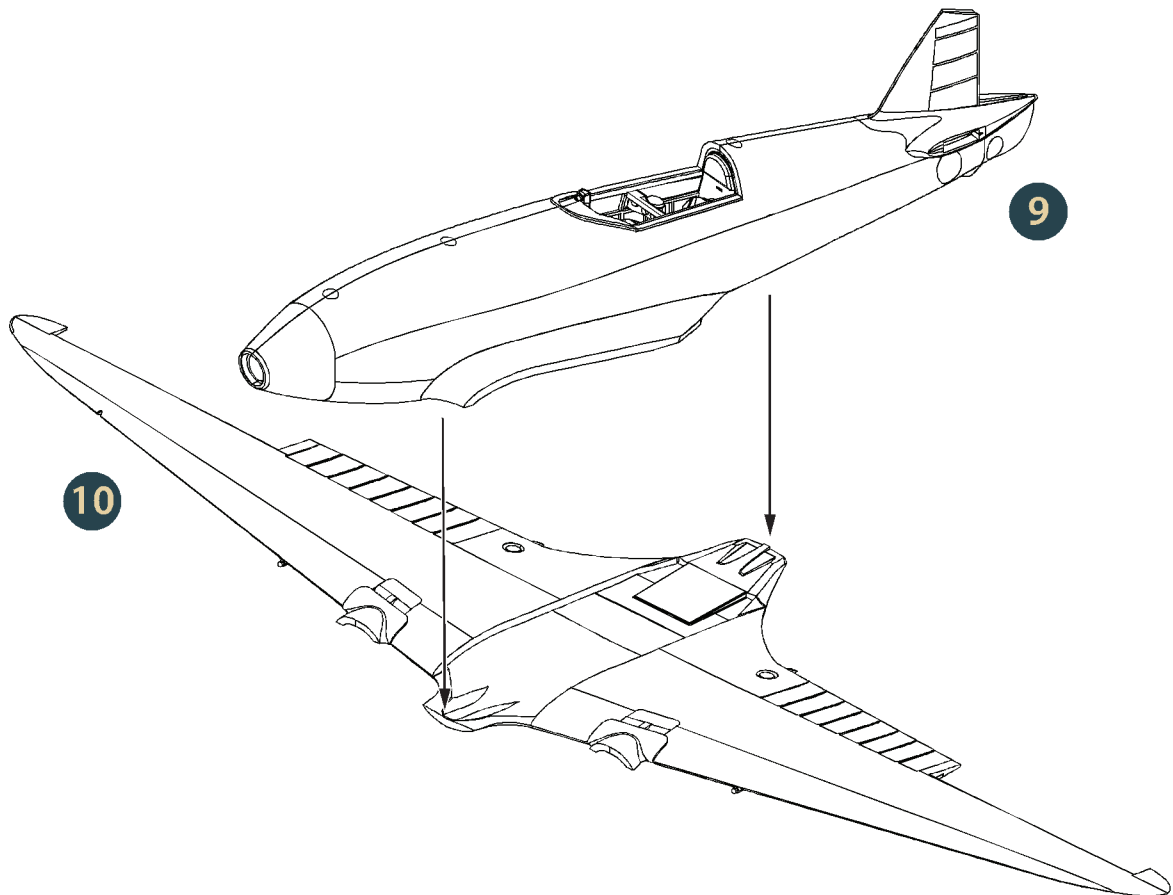

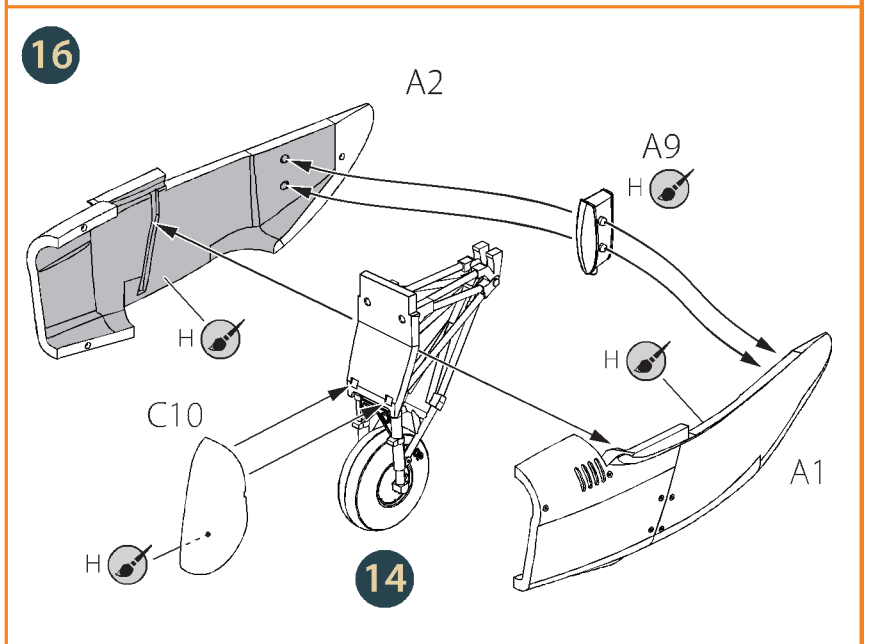
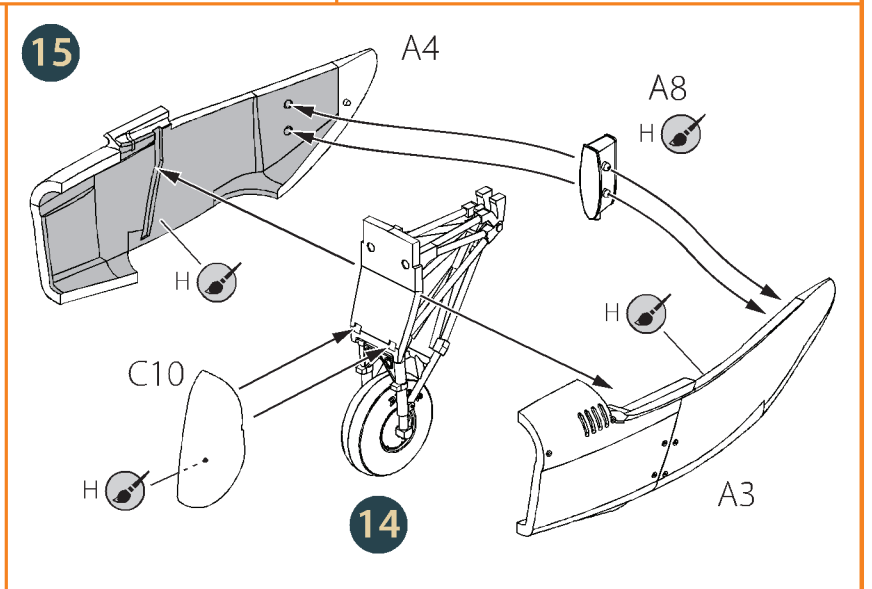
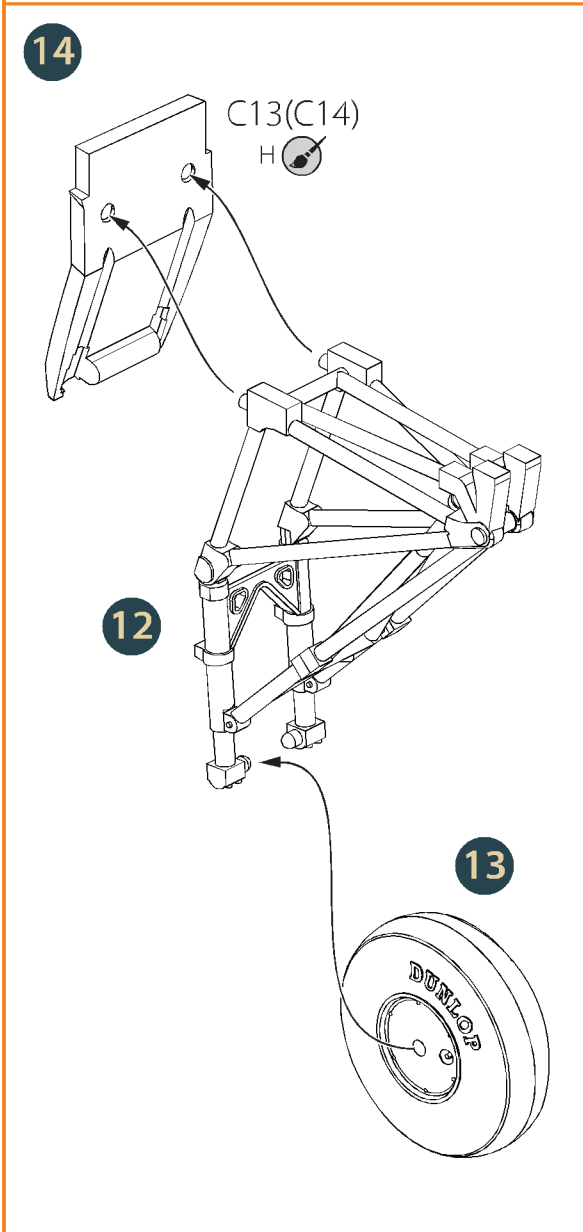
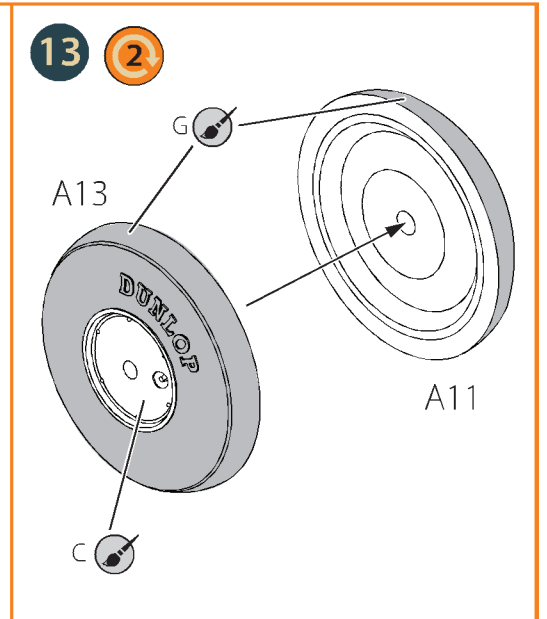
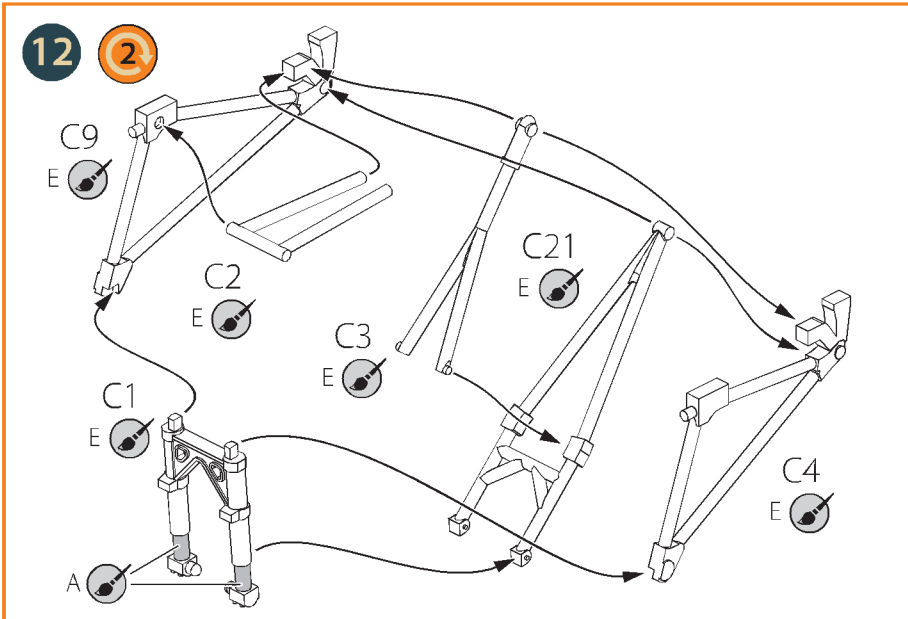

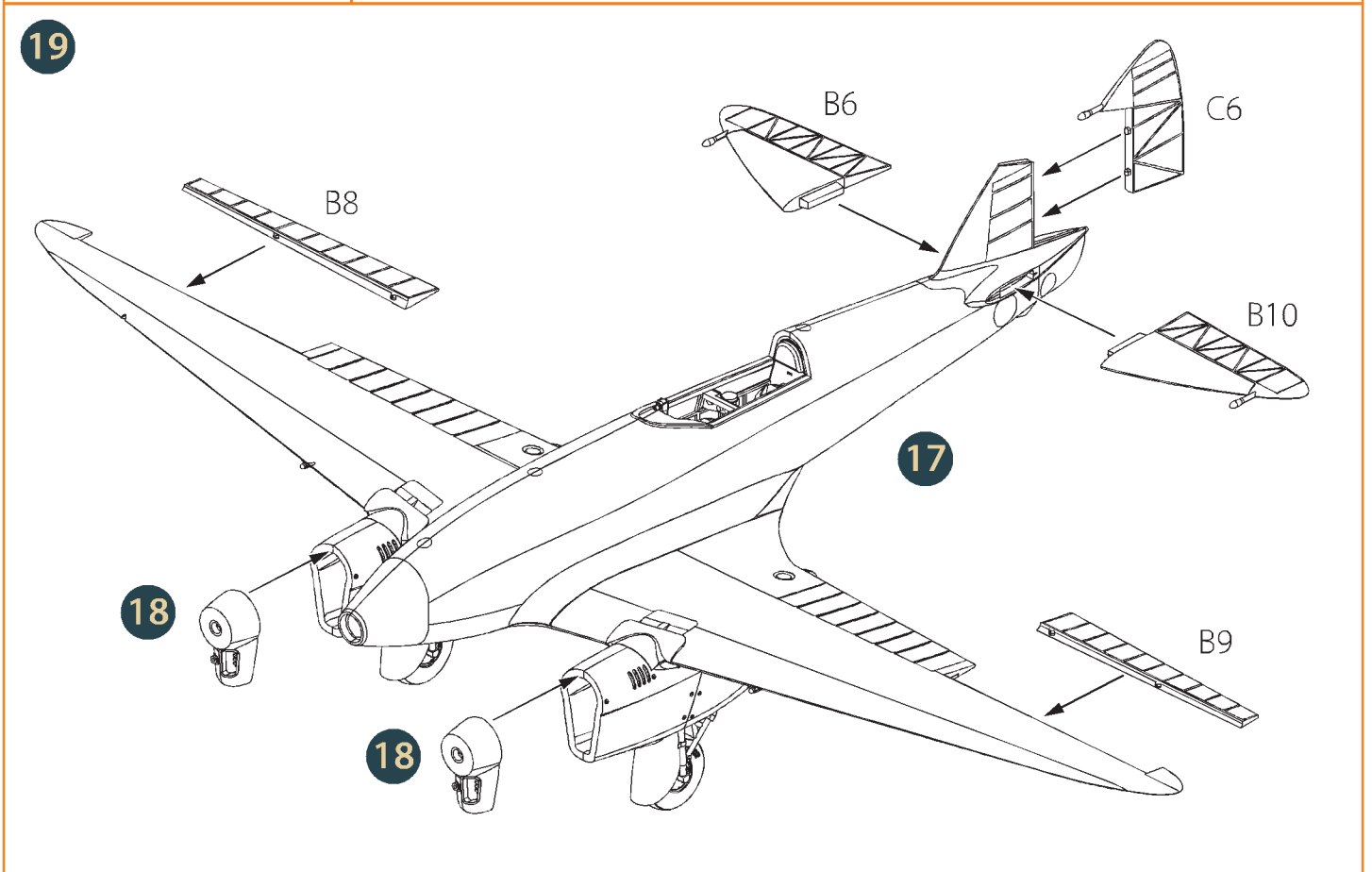
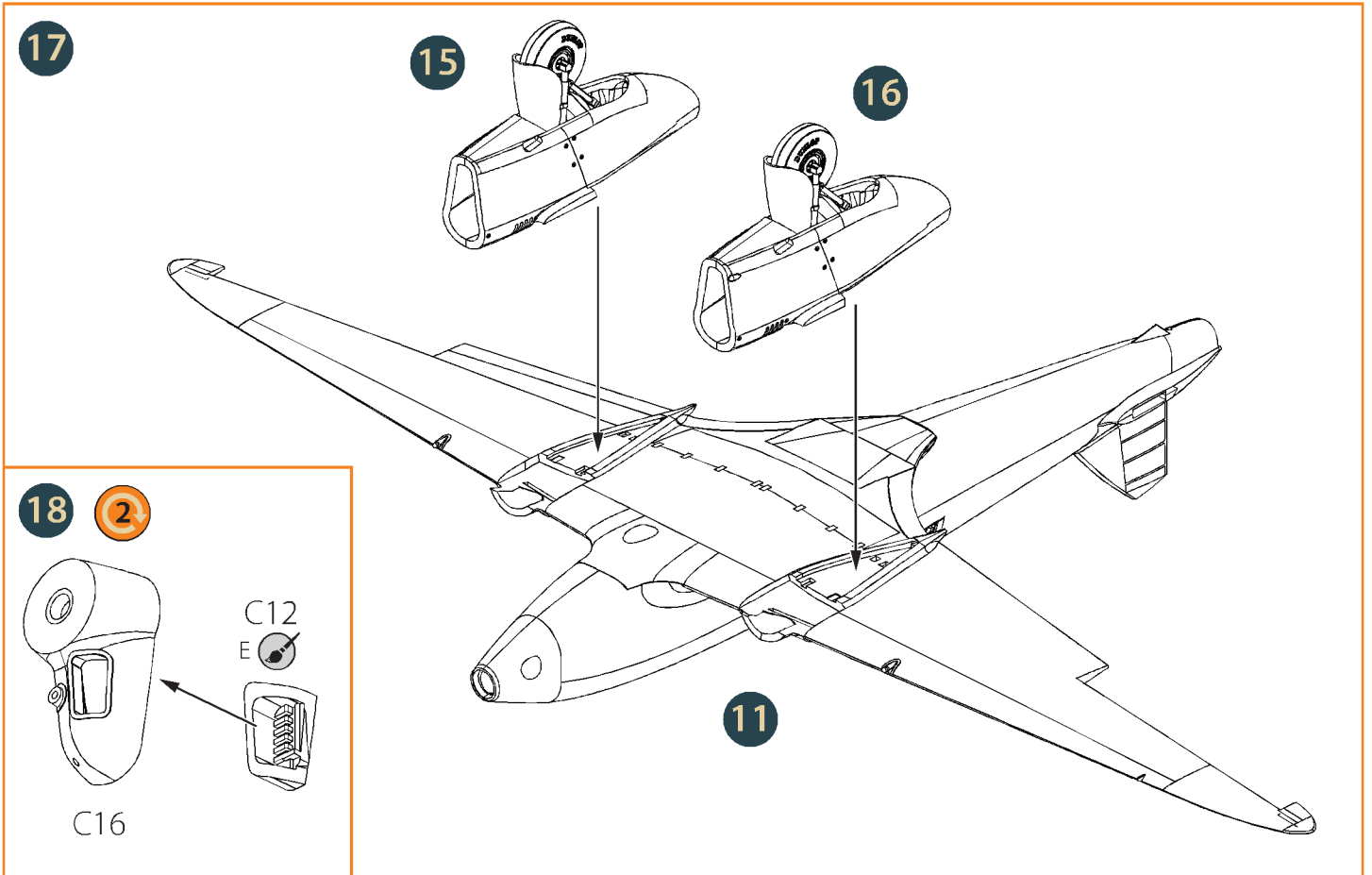

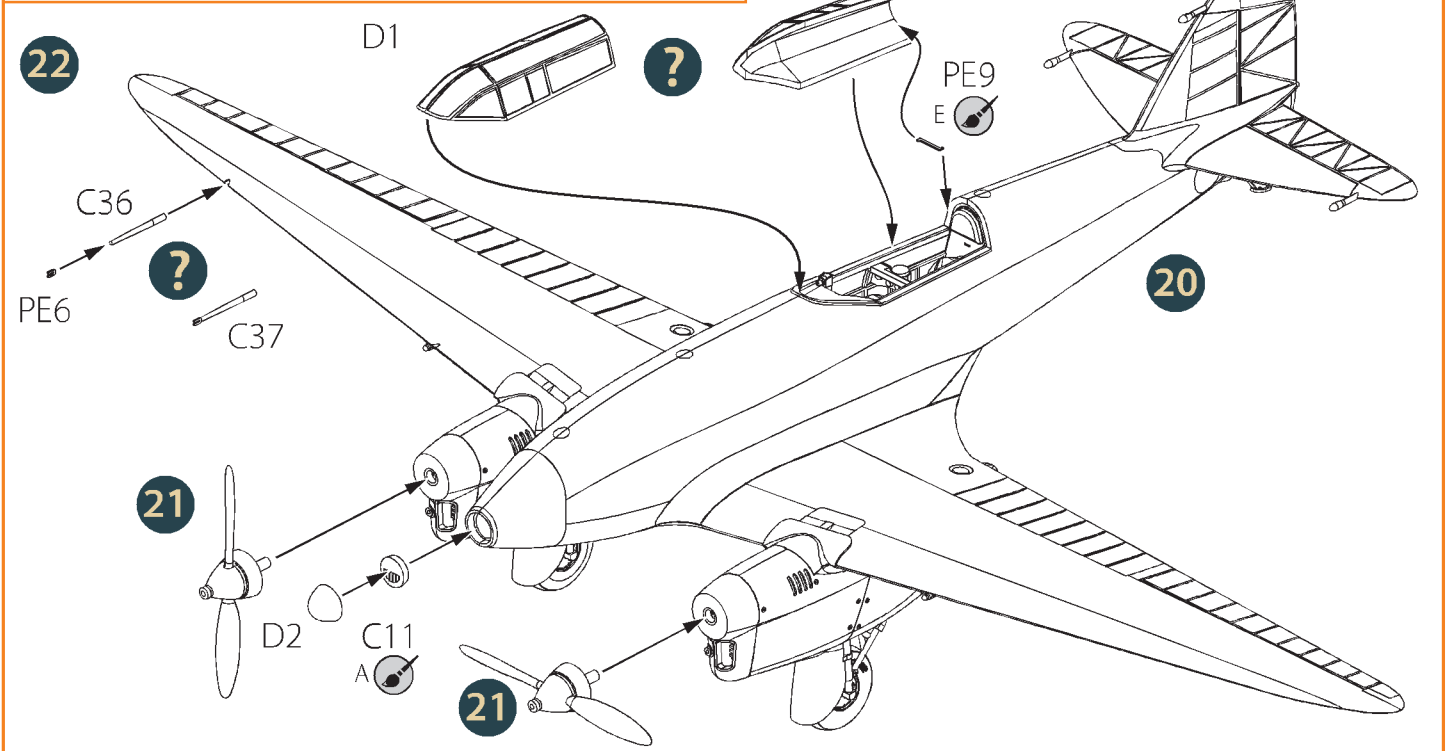
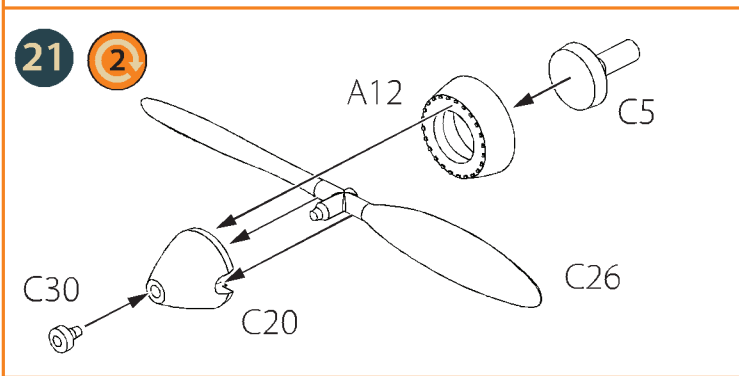
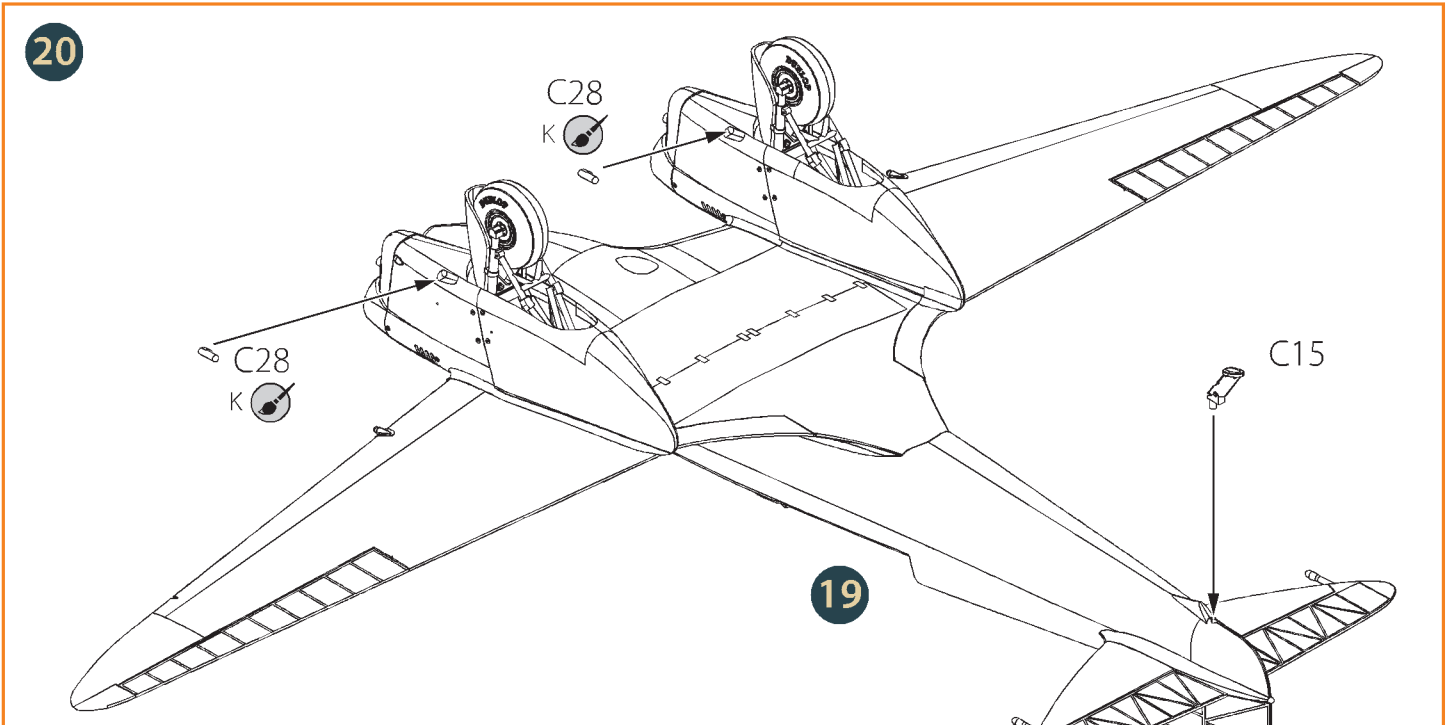

DH.88 Comet MacRobertson Trophy Air Race, 1934



MR. COLOR 8
A.MIG-0195
SILVER



MR. COLOR 383
A.MIG-0238
GREEN



MR. COLOR 33
A.MIG-0046
BLACK

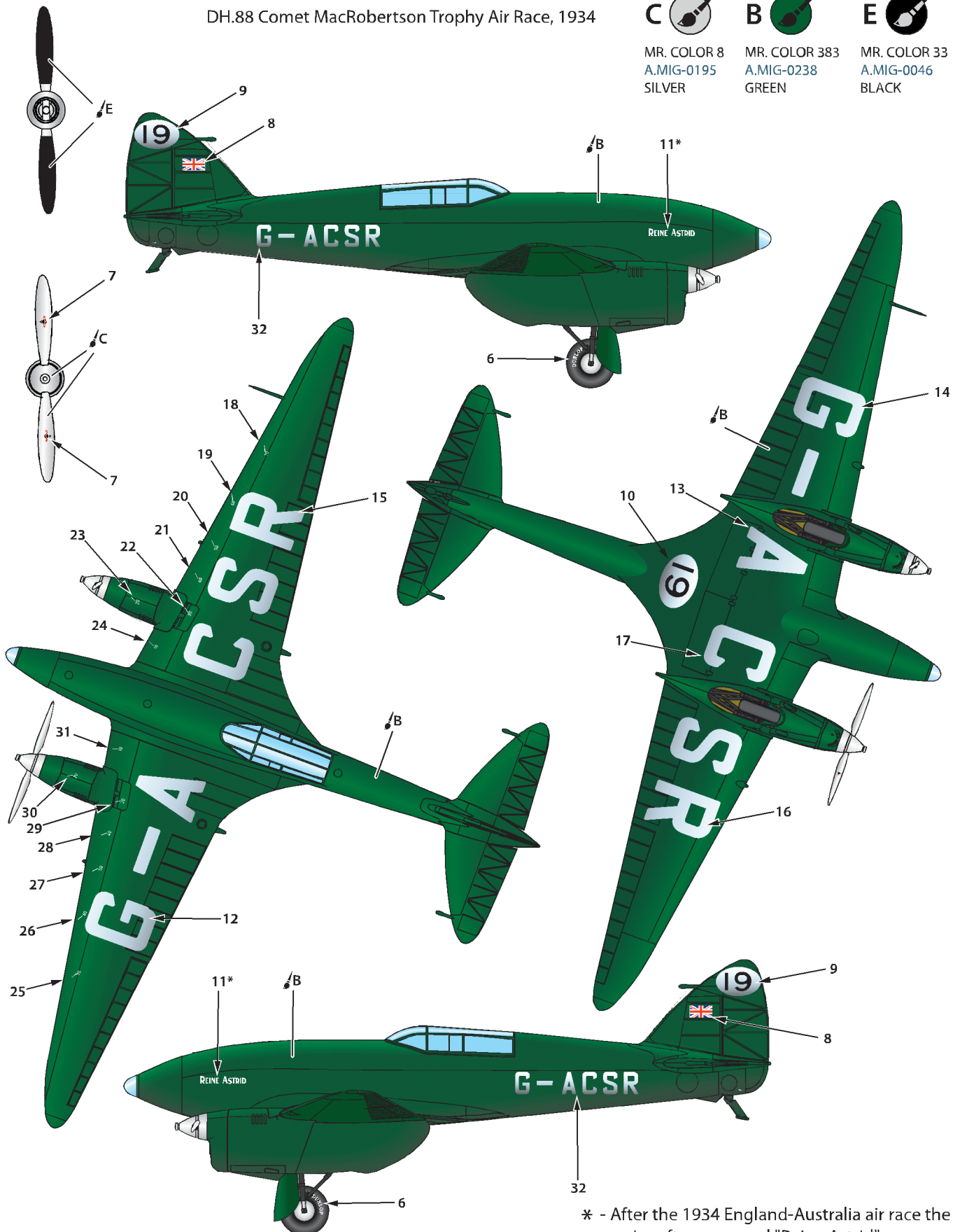

* - After the 1934 England-Australia air race the aircraft was named "Reine Astrid".



VISIT OUR SITE FOR MORE SCALE MODEL KITS

clearpropmodels.com



**DH.88.
VACUUM
FORMED
CANOPY**
ACCESSORIES SET

1:72
#CPA72042

EXTRA SET

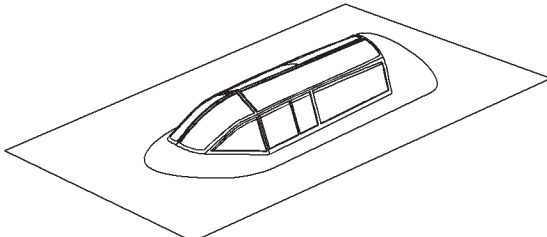

NUMBERS OF PARTS: 1 pcs



**DH.88
COMET**
ACCESSORIES SET FOR
CLEAR PROP KIT

1:72
#CPA72134

PAINTING MASK

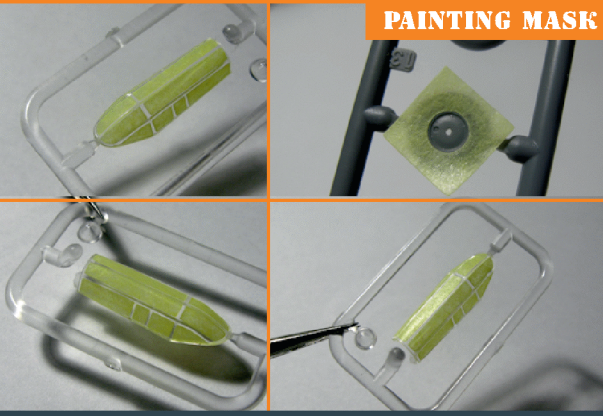

NUMBER OF PARTS: 16 pcs



**DH.88.
ENGINE**
ACCESSORIES SET

1:72
#CPA72141

EXTRA SET

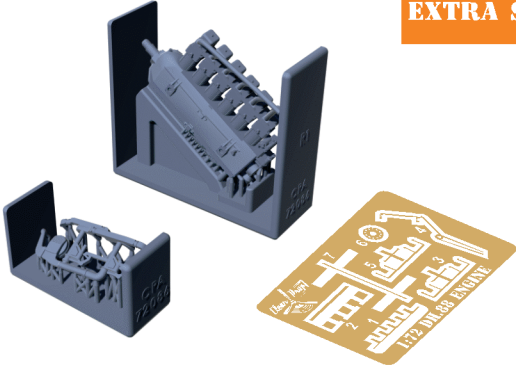

NUMBERS OF PARTS: 9 pcs



sales@clearpropmodels.com



www.fb.com/Clearpropmodels