

CH-37 Mojave 'US Army'

EN

In 1950 US Navy together with US Marines came out with specifications calling for big Assault Transport helicopter. The machine had to be capable of transporting 26 fully-equipped troops and also capable of being used for transportation of belly mounted cargoes or casualties.

According to these specifications, Sikorsky company begun design works on twin engined helicopter under factory designation S-56. Four prototypes with military designation XHR2S-1 were ordered in 1951. After successful trials US Marines had ordered series production of HR2S-1 that started to be delivered in 1956. The first machines passed difficult tests that led to changes in R-2800 engines cooling, addition of ventral fin and some additional modifications. Eventually, fifty five HR2S-1s were assigned to units. Pilots unofficially named the machine Deuce.

US Army was also very interested in the powerful helicopter. After testing one prototype series of modified S-56 designated H-37A and later modernized to H-37B version. The machines got the combat name Mojave. Under the 1962 United States Tri-Service aircraft designation system were the H-37A redesigned to CH-37A, H-37B to CH-37B and HR2S-1 to CH-37C.

HR2S-1s were assigned to HMH-461 and 462 operational squadrons, Army H-37s served both in USA and Germany.

Both US Marines and US Army machines were deployed to Vietnam. They served mainly for weapons and troops transports to combat zones. Also, they were used for transport of damaged helicopters slung below the fuselage.

The surviving machines were handed over to National Guards and eventually displaced in 1974.

Technical data:

Main rotor diameter: 21.95m, Tail rotor diameter: 4.57m, Fuselage length: 19.76m, Max. Speed: 209 kmh, Max. Climb rate: 4362 m/s, Service ceiling: 2 650m, Range: 233m

CZ

V roce 1950 společně vedení US NAVY a US Marines zformulovalo požadavky na velký „útočný, vylodovací a výsadkový vrtulník“ Stroj měl být schopen přepravy celého ozbrojeného družstva, zároveň měl být použitelný například k přepravě raněných nebo transportu nákladů pod trupem.

Dle těchto požadavků začala firma Sikorsky konstruovat dvumotorový typ pod továrním označením S-56. V roce 1951 byly objednány čtyři prototypy s vojenským označením XHR2S-1. Na základě úspěšných zkoušek objednalo US Marines sériové vrtulníky HR2S-1. Ty začalo US Marines přebírat v roce 1956. První stroje prošly náročnými testy, na jejichž základě byly uskutečněny změny v chlazení motorů R-2800, byl přidán kýl k ocasní ploše a provedeny další úpravy. Nakonec bylo do výzbroje zařazeno padesát pět kusů HR2S-1. Od pilotů obdržely neoficiální přezdívku Deuce.

US Army projevilo o výkonný vrtulník velký zájem. Po vyzkoušení jednoho prototypu objednalo sérii upravených S-56 pod označením H-37A, později modernizovaných na verzi H-37B. Stroje dostaly bojové jméno Mojave. V rámci unifikace označení v roce 1962 byly H-37A přeznačeny na CH-37A, H-37B na CH-37B a HR2S-1 na CH-37C.

HR2S-1 sloužily u operačních squadron HMH-461 a 462, armádní H-37 sloužily jak na území USA, tak v Německu.

Stroje jak US Marines, tak US Army se dočkaly nasazení ve Vietnamu. Sloužily zejména k přepravě zbraní a vojáků do bojových prostorů. Používaly byly i k transportu poškozených vrtulníků na závěsu pod trupem.

Přeživší stroje byly předány jednotkám Národní Gardy a vyřazeny byly definitivně v roce 1974

Tech. údaje:

Průměr hl. rotoru: 21,95 m, průměr vyr. rotoru: 4,57 m, délka trupu: 19,76 m, max. rychlost: 209 km/h, max. stoupavost: 4,62 m/s, dostup: 2 650 m, dolet: 233 m

We would like to thank to Mr. Donald Hinton and Ralph B. Young for their invaluable help during the preparation of this kit.

Děkujeme Donu Hintonovi a Ralphu B. Youngovi za jejich neocenitelnou pomoc při přípravě tohoto modelu.

PLASTIC PARTS

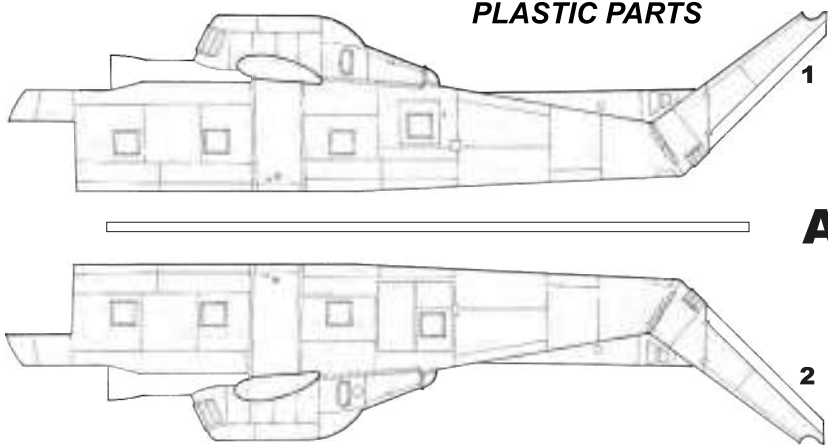

A

B

PUR PARTS (PUR)

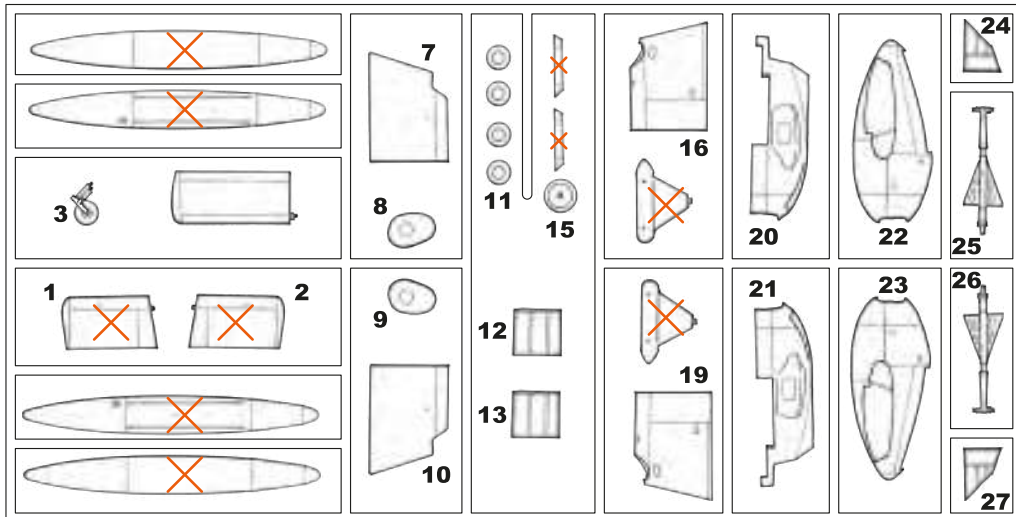
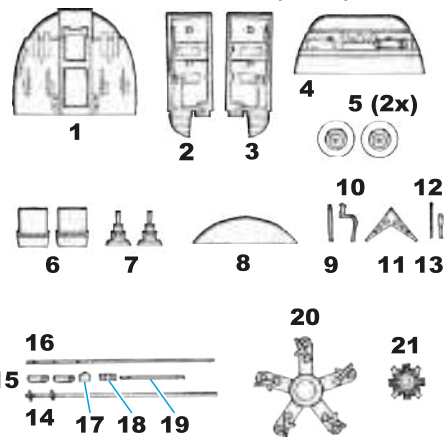

FILM

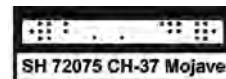

CLEAR PARTS (CP)

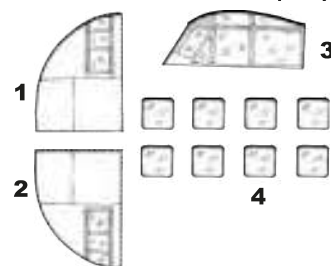

SPECIAL MASK

Tip and trick
For easier assembly we recommend use our pre-cut mask M72046, sold separately.

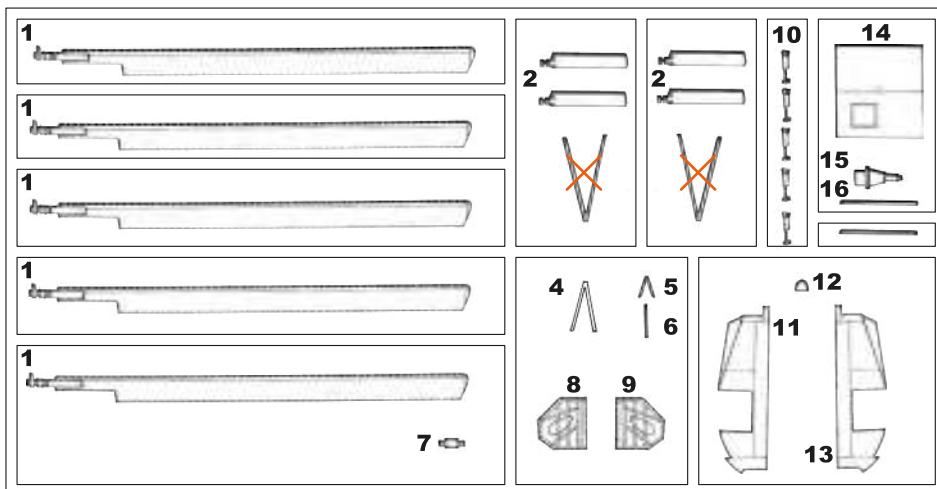
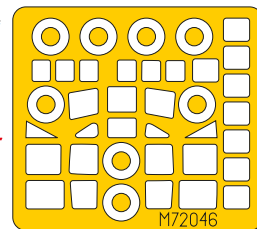

C

PHOTO-ETCHED PARTS (PP)

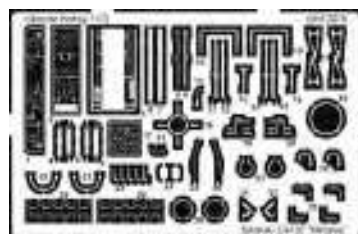

D

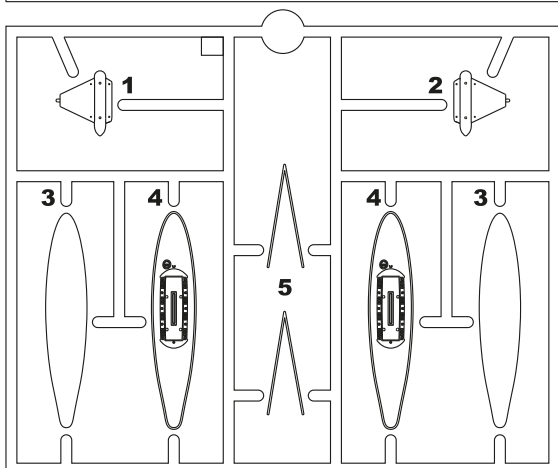

Barvy GUNZE / GUNZE Colour No.

(A)	Bílá / White	H21 / C69
(B)	Černá / Black	H12 / C33
(C)	Opálený kov / Burn Metal	H76 / C61
(D)	Žlutá / Yellow	H4 / C4
(E)	Pneu šedá / Tyre Black	H77 / C137
(F)	Tmavý kov / Dark iron	MC214
(G)	Inter. žlutá / Interior Yellow	H313 / C313
(H)	Stříbrná / Silver	H8 / C8
(I)	Kůže / Leather	H17 / C29
(J)	Chrom / Chrome	MC211
(K)	Ocel.šedá / Steel Grey	H75 / C25
(L)	Interiérová šedá / Interior Grey	H308 / C308
(M)	Plátno / Linen	H85 / C45
(N)	Červená / Red	H3 / C3
(O)	Nevýrazná olivová / Olive Drab	H304 / C304

X Tento díl nepoužít
Do not use this part

SYMBOLS

? MOŽNOST VOLBY
OPTIONAL
NACH BELIEBEN
OPTION

👉 POUŽÍT KYANOAKRYLÁTOVÉ LEPIDLO
INSTANT CYANOACRYLATE GLUE
ZYANOAKRYLATKLEBER
ADHÉSIF CYANOACRYLAT

↪ OHNOUT
BEND
BIEGEN
COURBER

👉 ZHOTOVIT NOVÉ
SCRATCH BUILD
FERTIGSTELLEN
ACHEVER

👉 ŘEZAT/VRTAT
CUT OFF/DRILL
ENTFERNEN
DETACHER

A NATRÍT
COLOUR
FARBEN
PEINDRE
GSI colours code

STEP 1

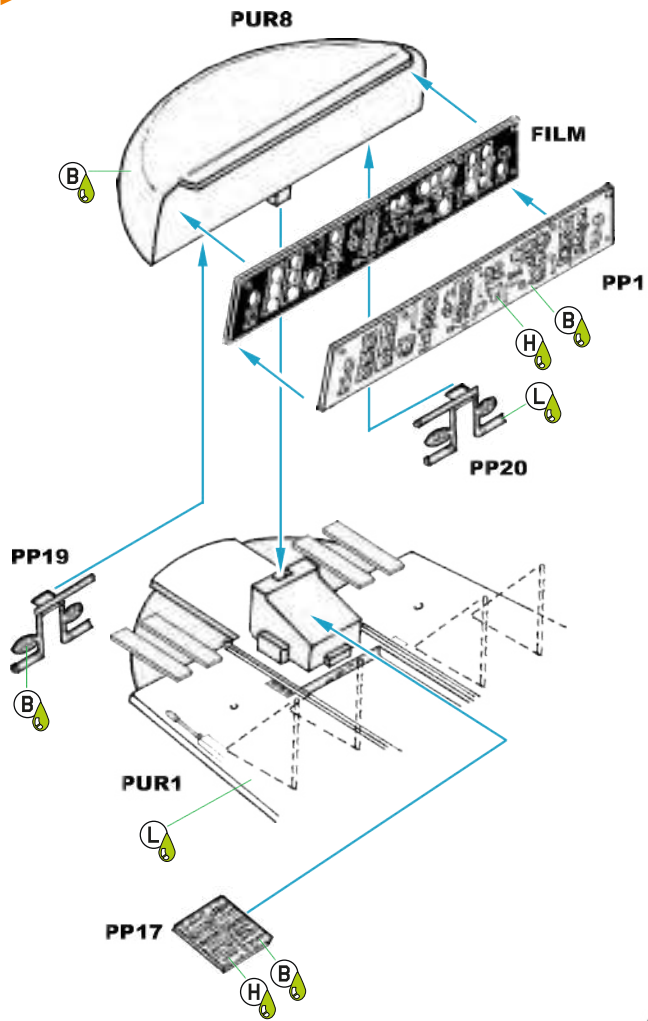

STEP 2

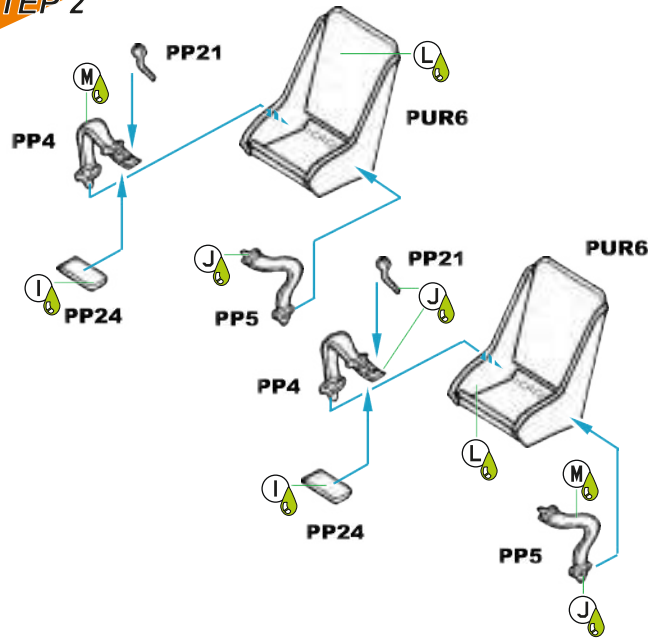

STEP 3

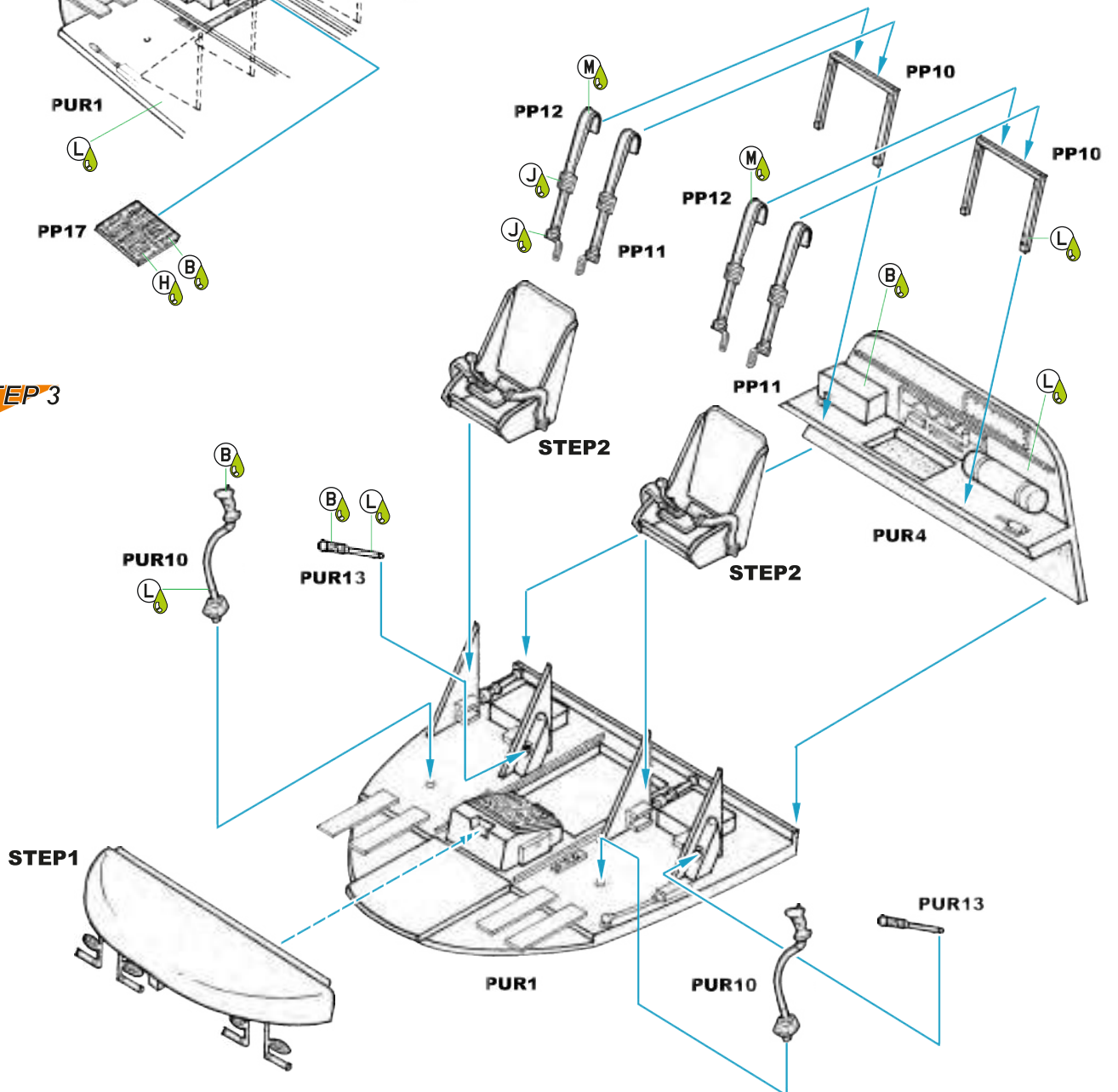

STEP 7

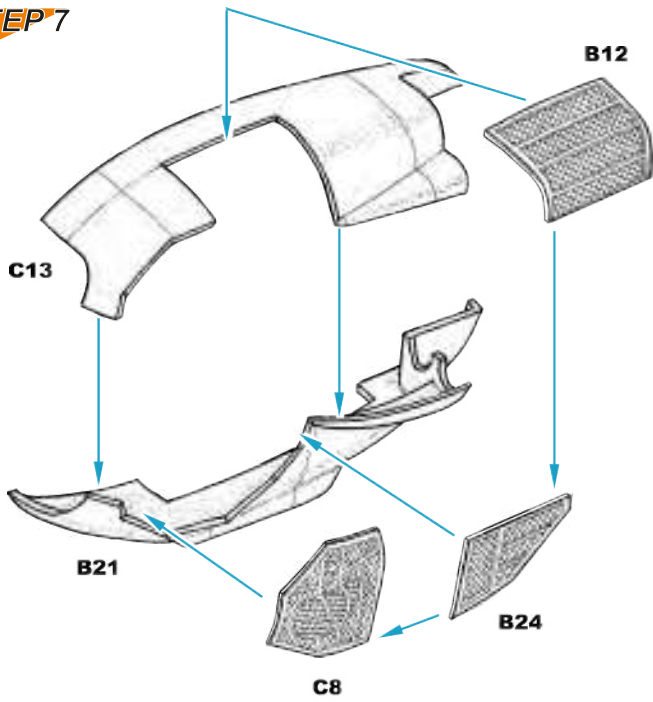

STEP 8

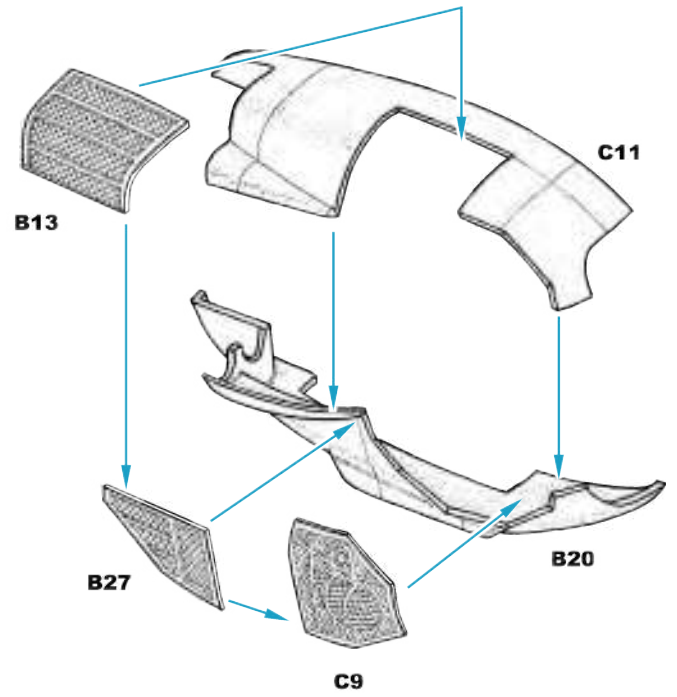

STEP 9

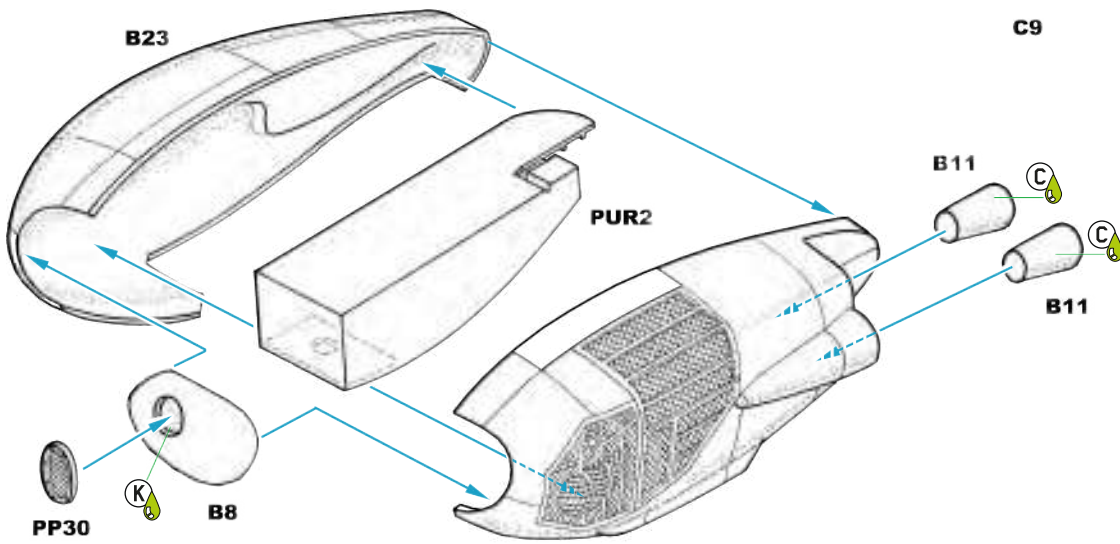

STEP 10

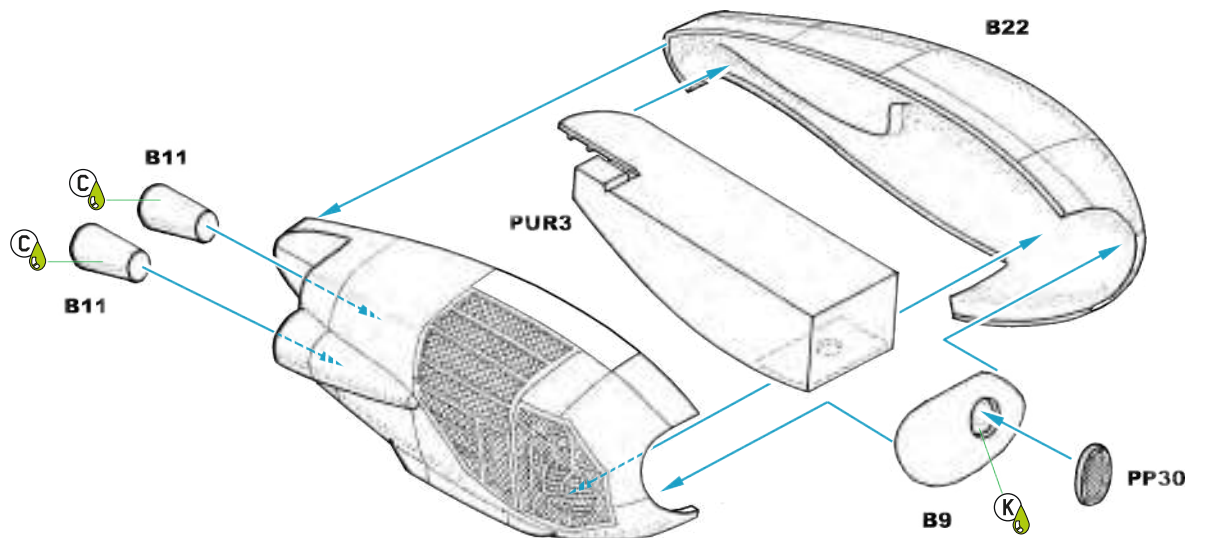

STEP 11

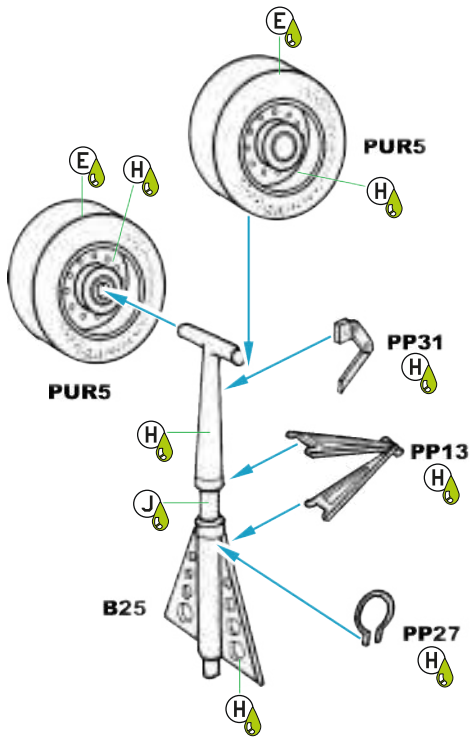

STEP 12

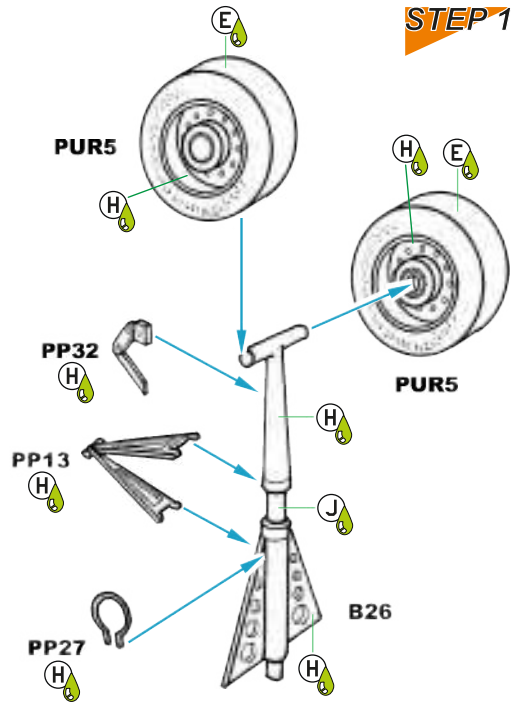

STEP 13

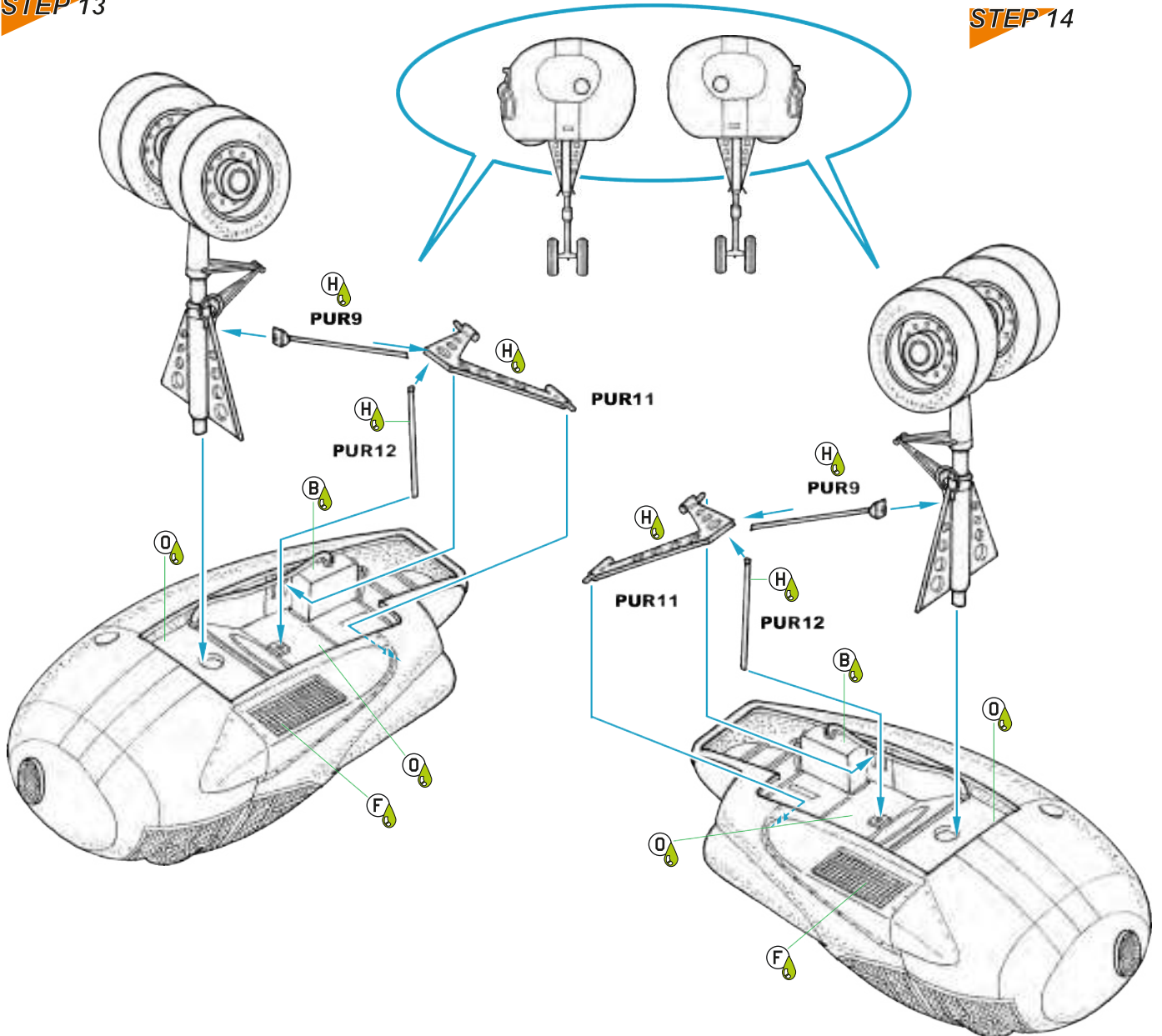

STEP 14

STEP 15

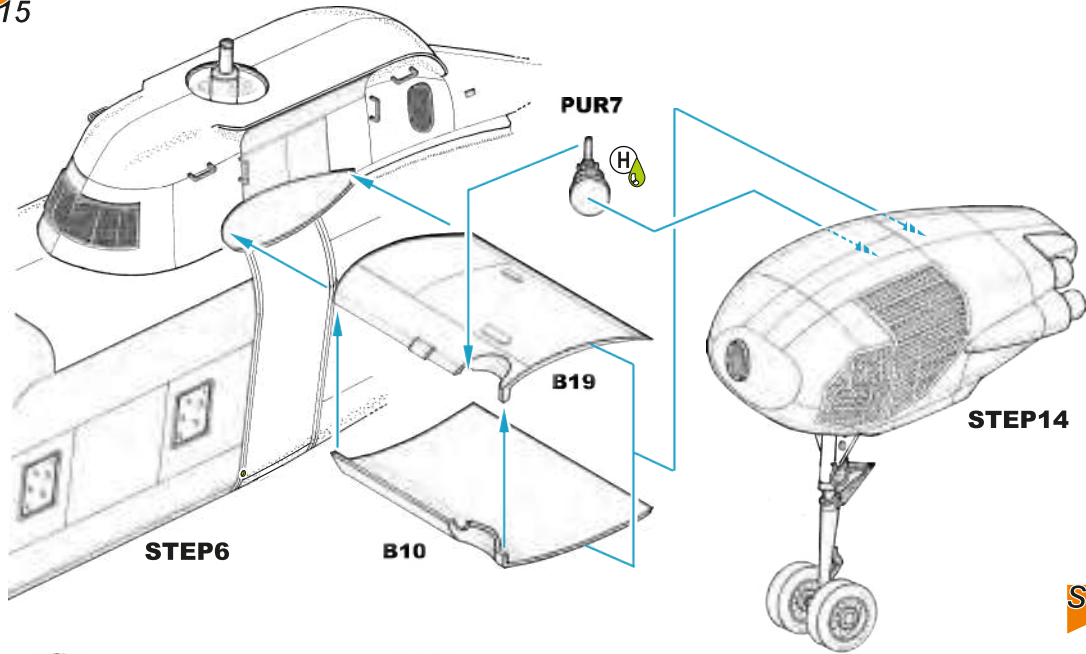

STEP 16

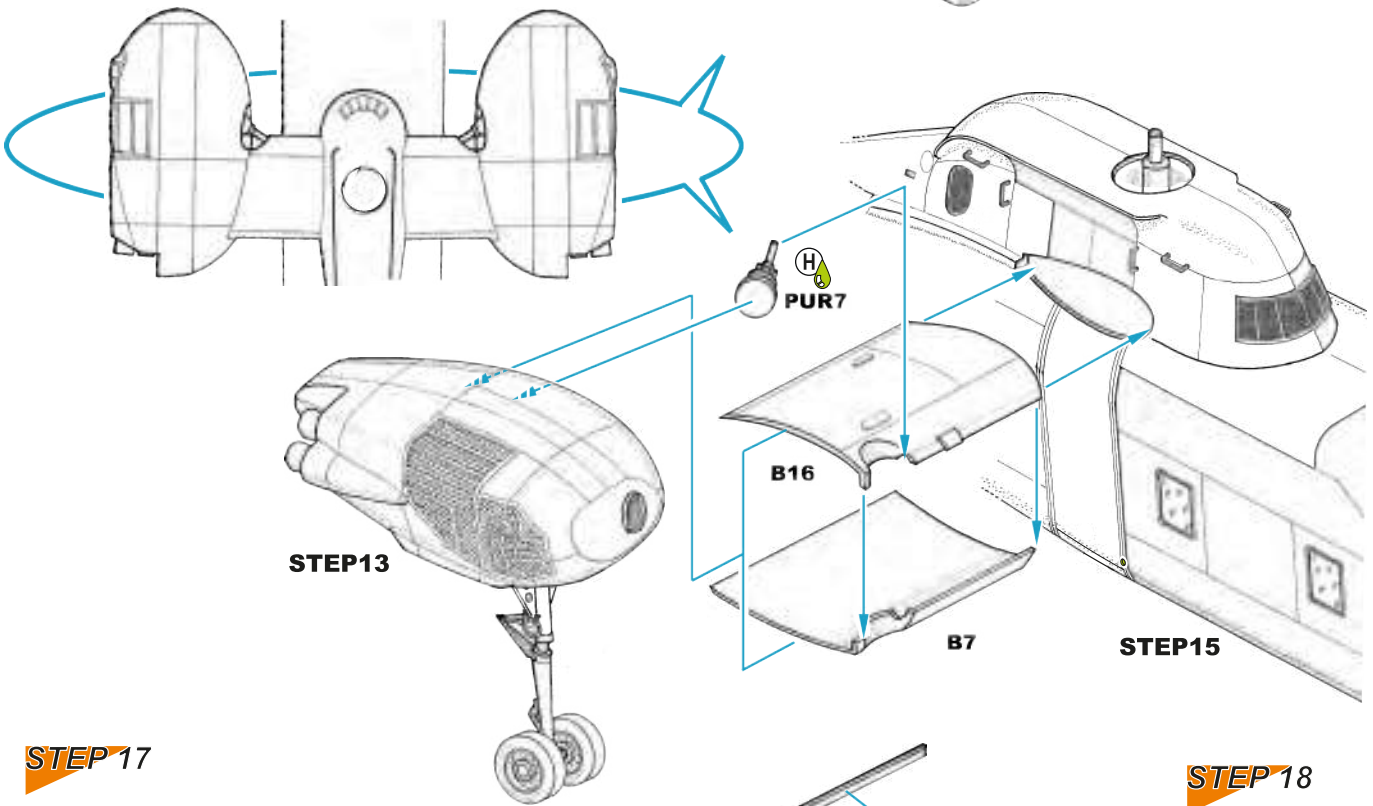

STEP 17

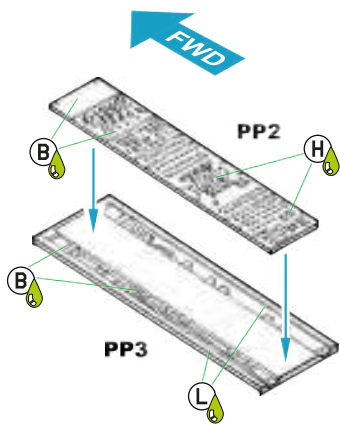

STEP 18

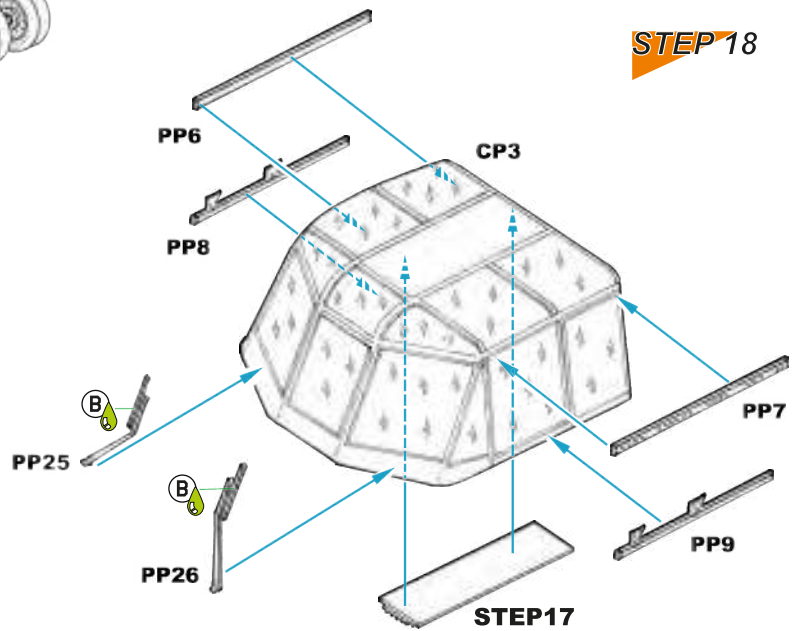

STEP 19

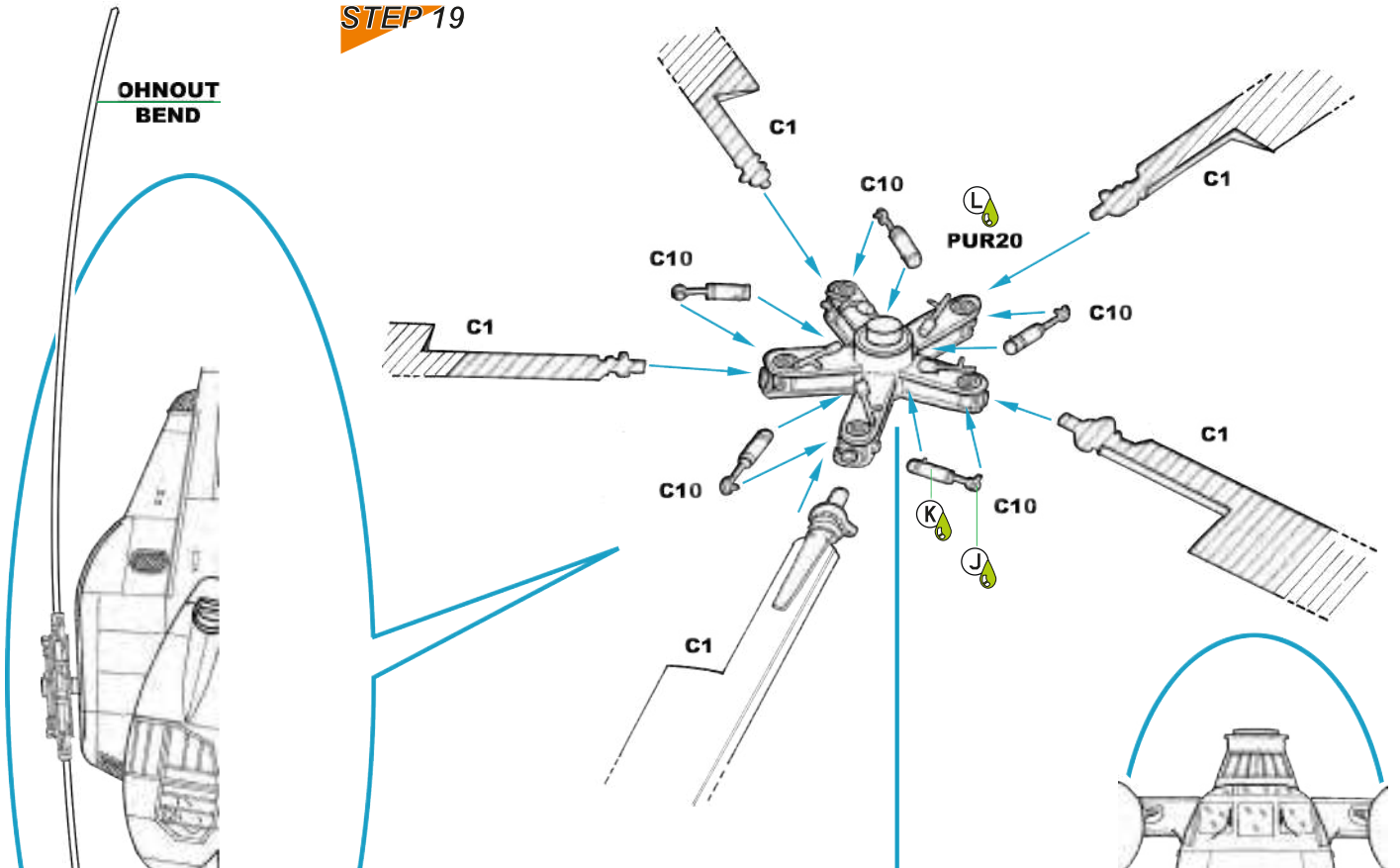

STEP 20

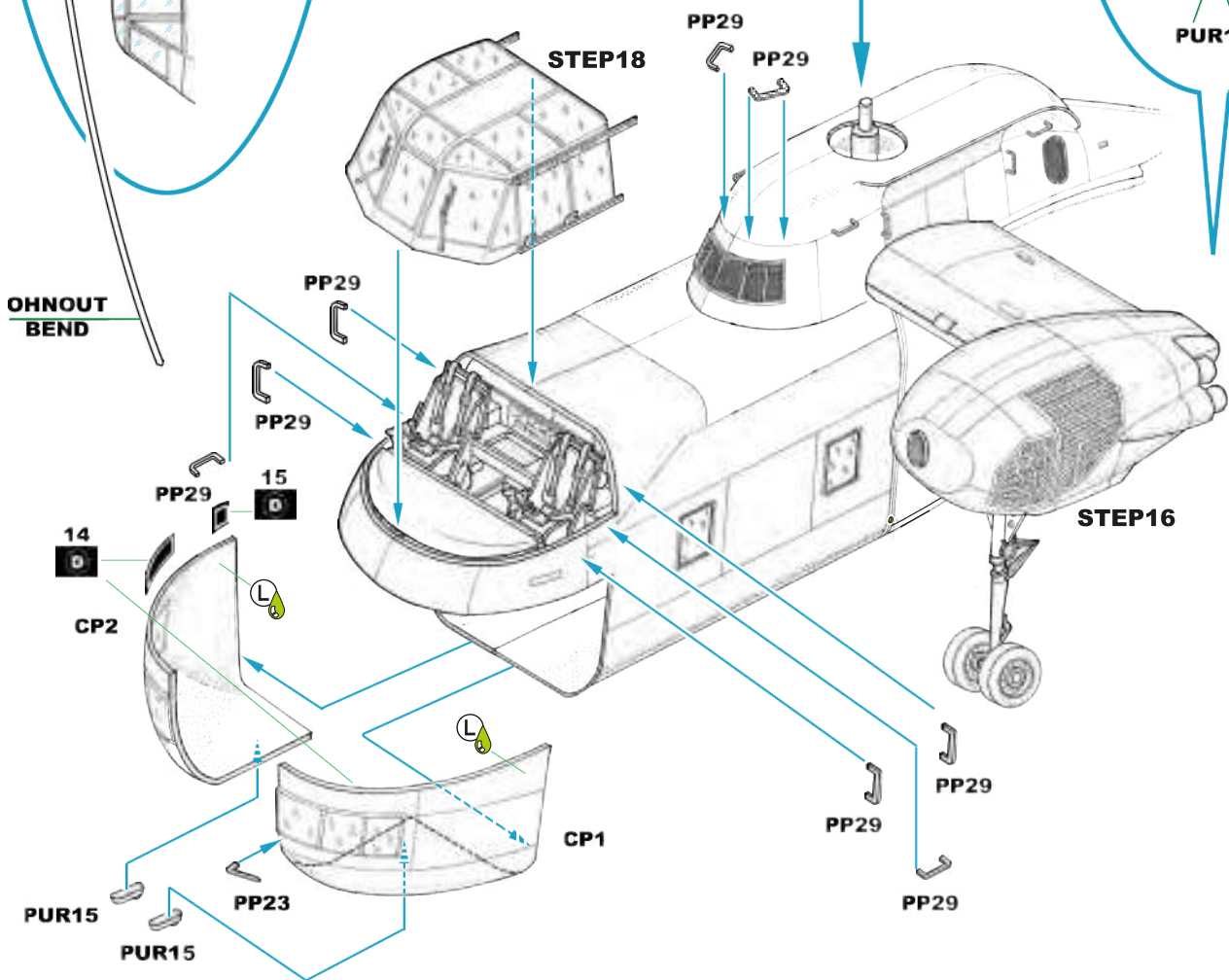

STEP 21

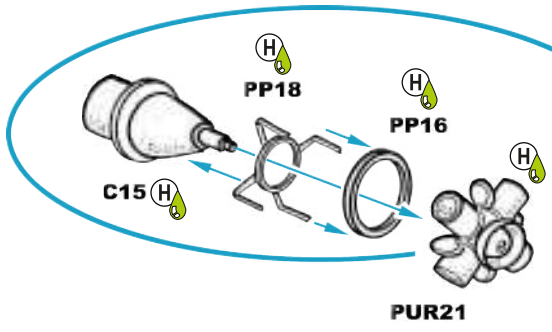

STEP 22

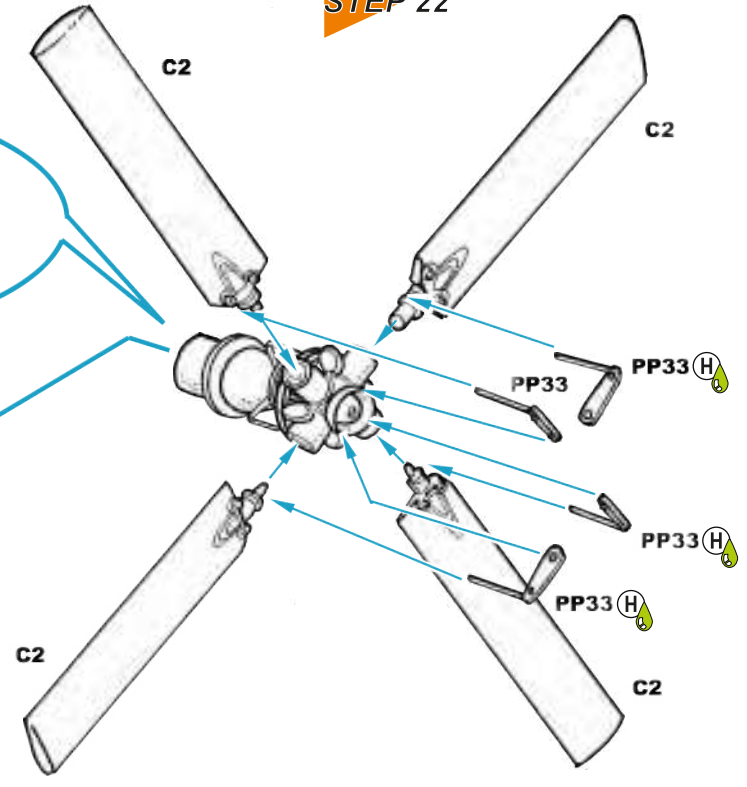

STEP 20

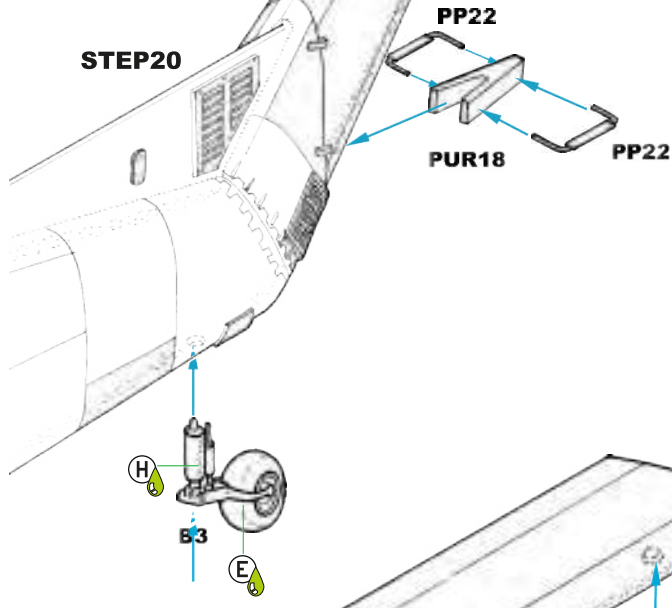

STEP 23

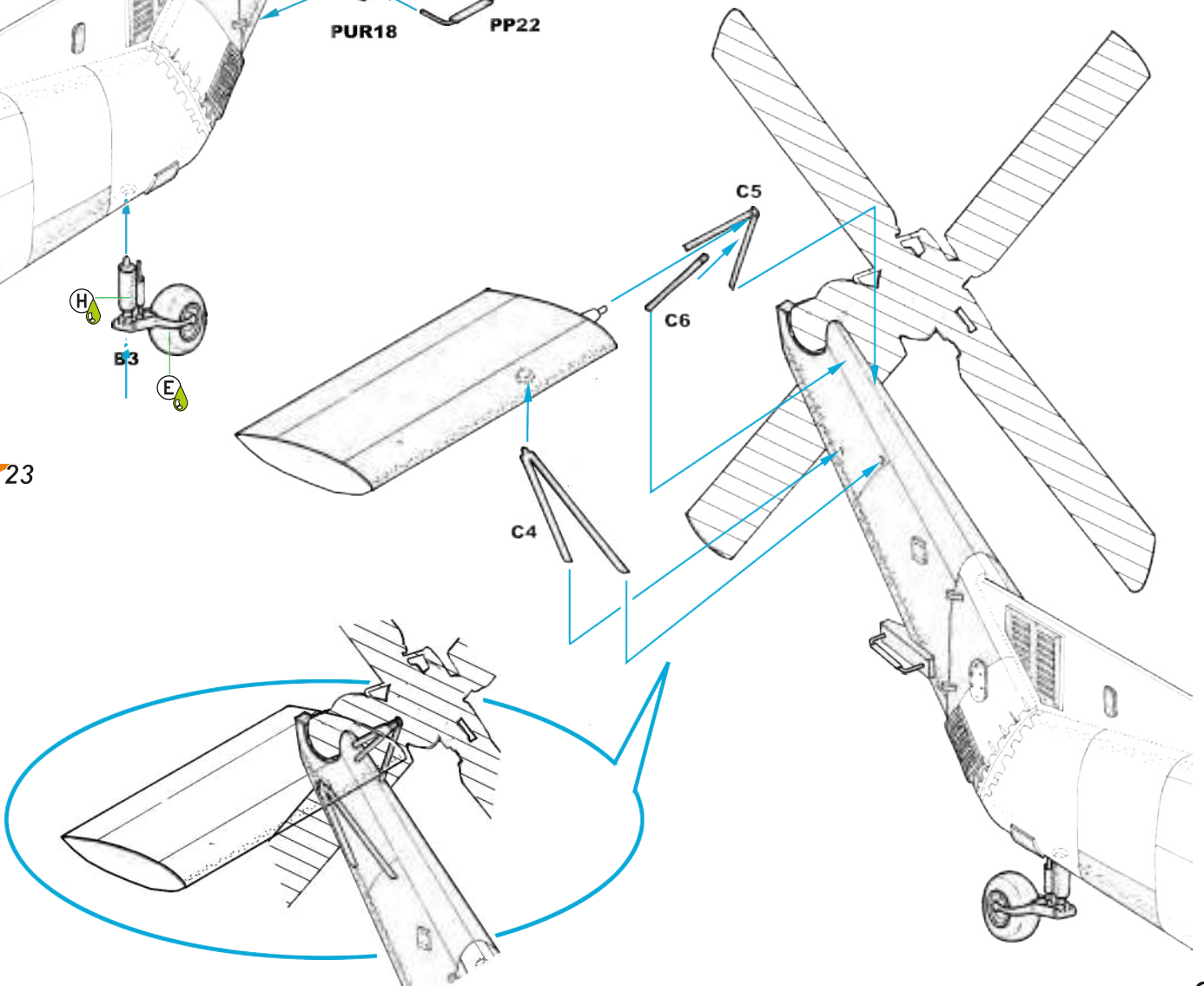

STEP 24

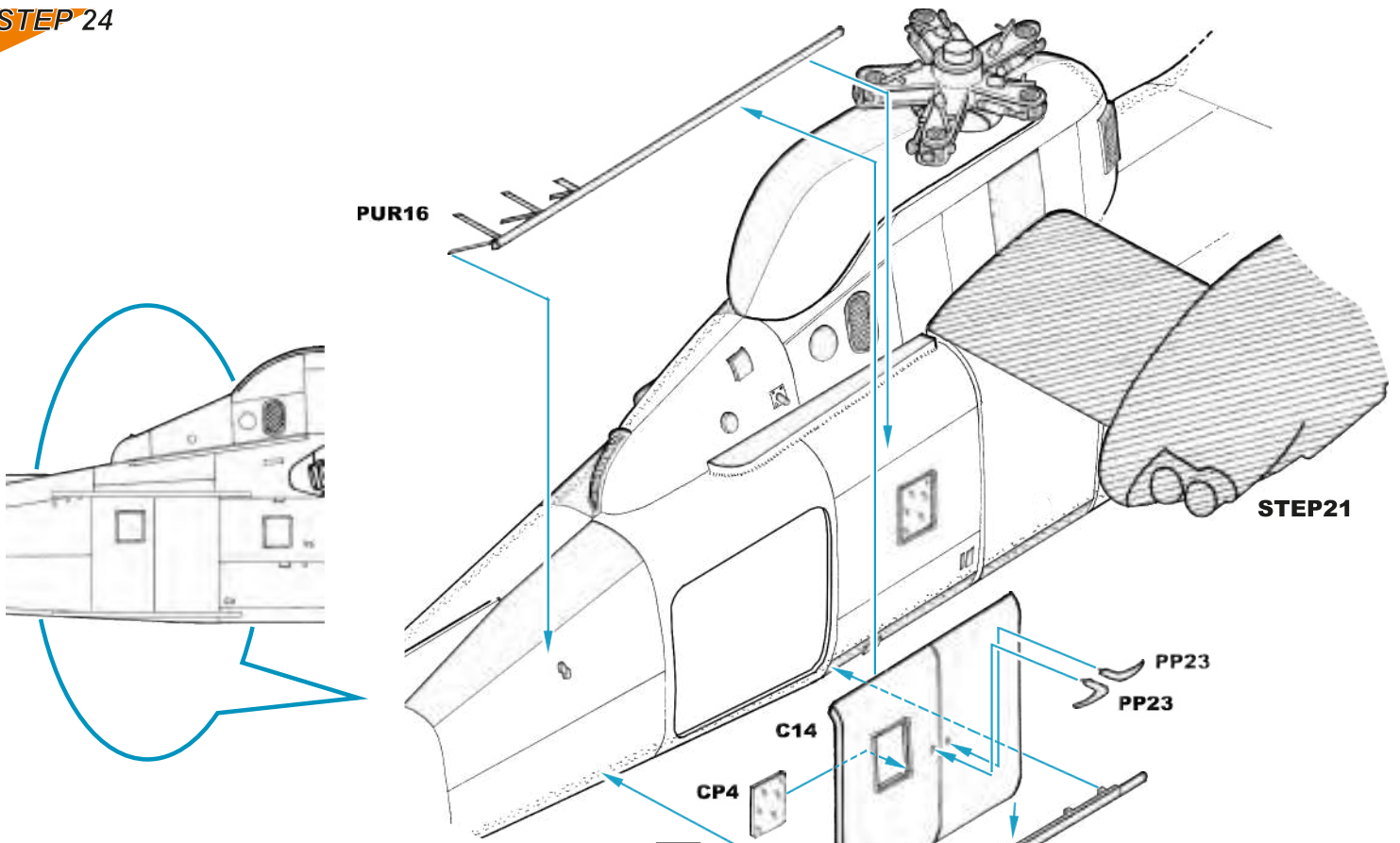

STEP 25

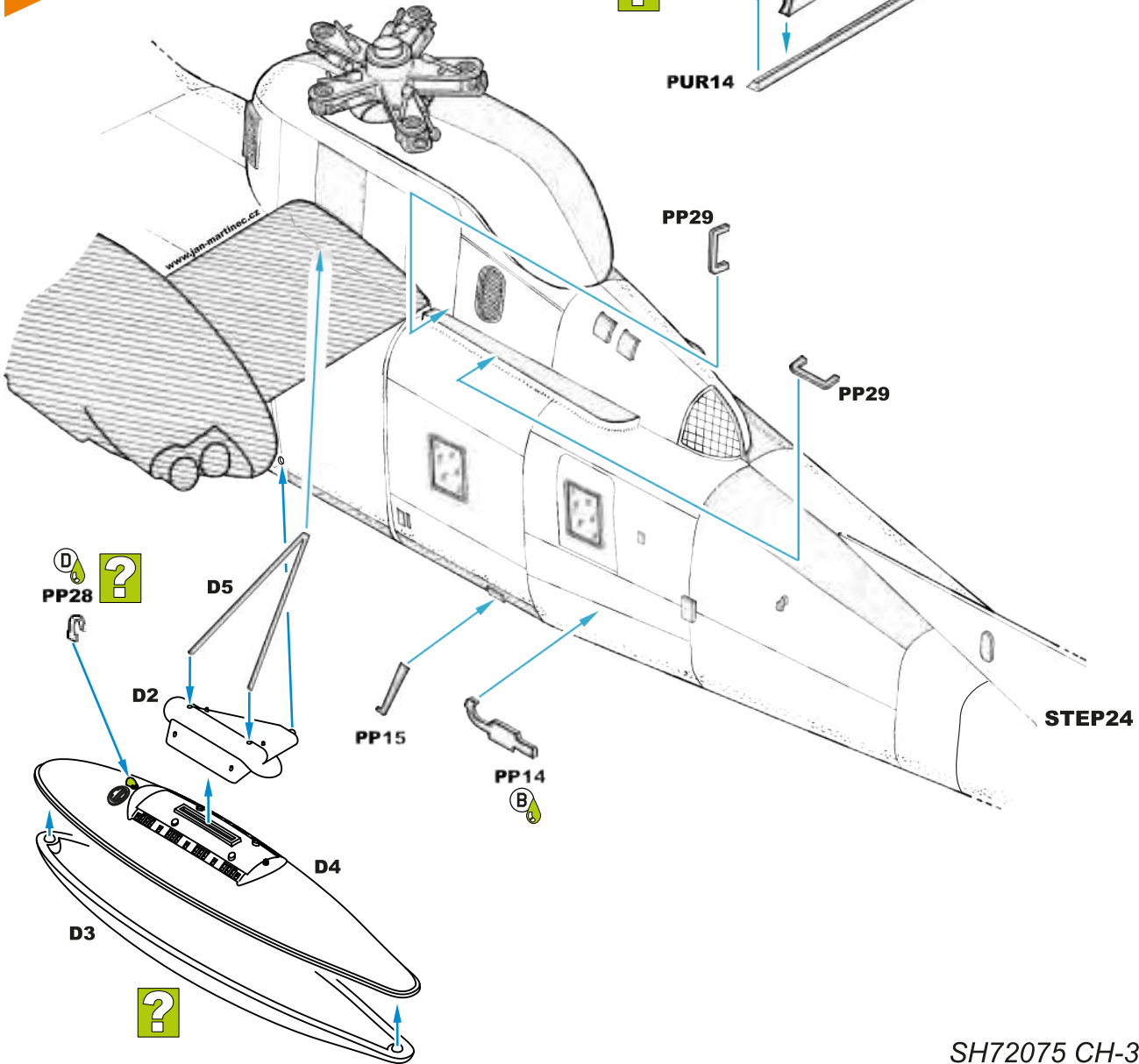

STEP 26

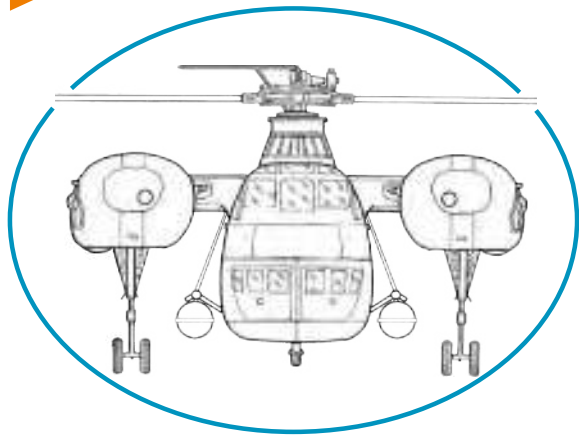

STEP 23

PUR17

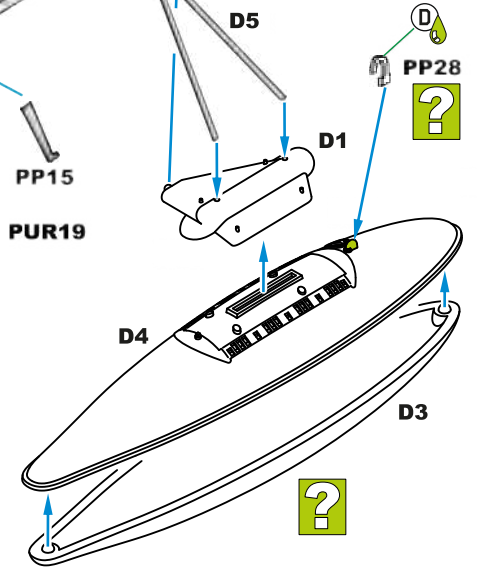

129-H1011 SANDING STICK – Four different grits of sanding papers on one sanding stick.



H1020 Razor Saw Profi Set



A new type handle for our razor saws.

Also contains H1018 and H1019 spare saws.

H1018
Triangle Razor Saw (1pc)



H1019
Multi-Shift Razor Saw (1pc)



CH-37B Mojave s/n 54-998, "Wayne's Work Horse", Blue Spring Flight, Da Nang AFB 1964. This machine was flown by CW2 Ted Jenkins as a part of the USAF secret RVP operations, code named "Blue Spring". In 1964 the "Wayne's Work Horse" sported white eyeballs with blue pupils and red lashes on the engines nacelles.

CH-37B Mojave s/n 54-998, "Wayne's Work Horse", Blue Spring Flight, Da Nang AFB 1964. Na tomto stroji létal CW2 Ted Jenkins v rámci tajných RPV operací USAF s kódovým názvem Blue Spring. V roce 1964 měl "Wayne's Work Horse" na motorových gondolách namalovány bílé oči s modrými zorničkami a červenými řasami.

SCHEME A

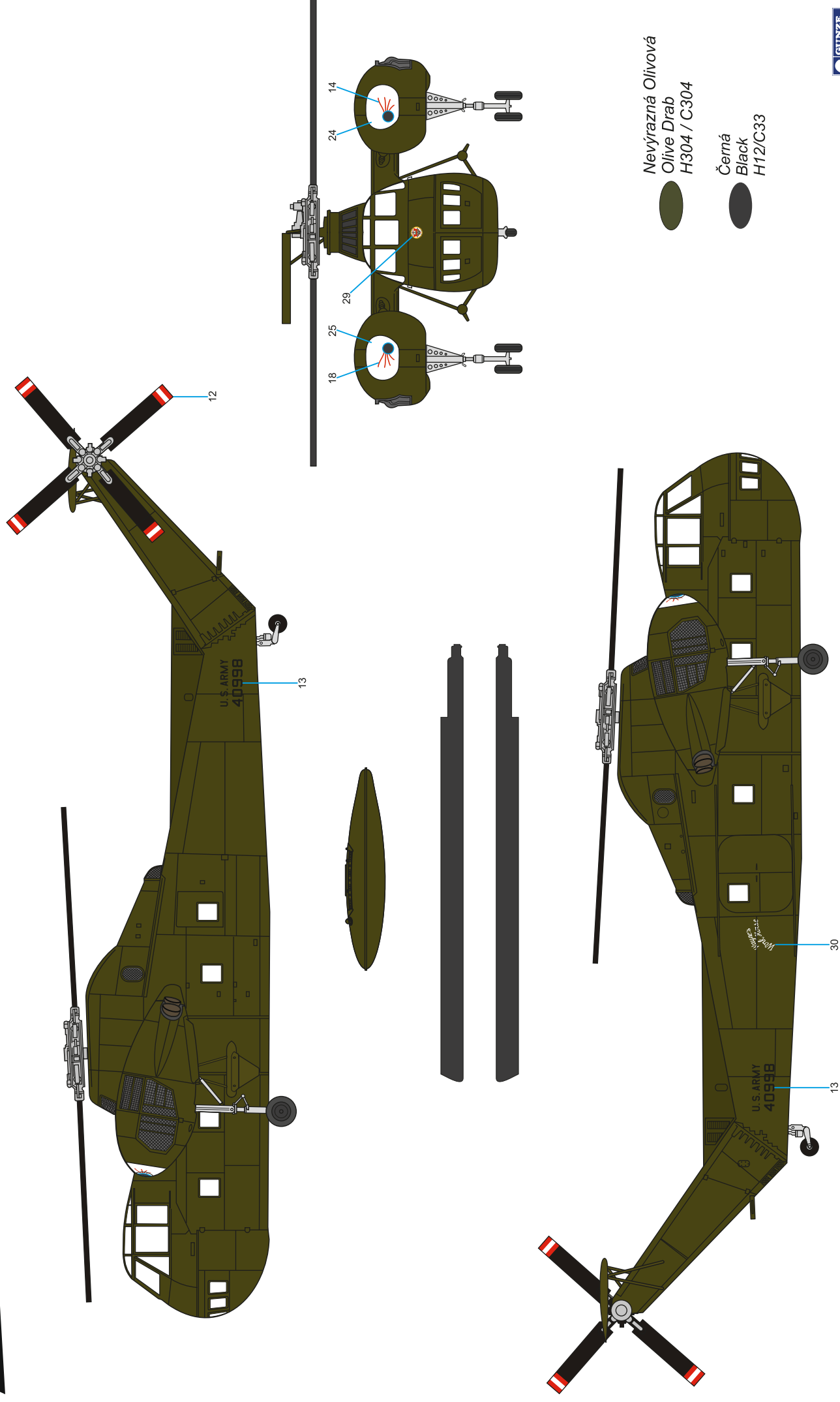

CH-37B Mojave s/n 54-998, "Wayne's Work Horse", Blue Spring Flight, Da Nang AFB 1965. In the beginning of 1965 the blue pupils and red lashes were removed from the white eyeballs on the engines nacelles.

CH-37B Mojave s/n 54-998, "Wayne's Work Horse", Blue Spring Flight, Da Nang AFB 1965. Počátkem roku 1965 byly odstraněny modré zorničky a červené řasy z bílých očí na motorových gondolách.

SCHEME B

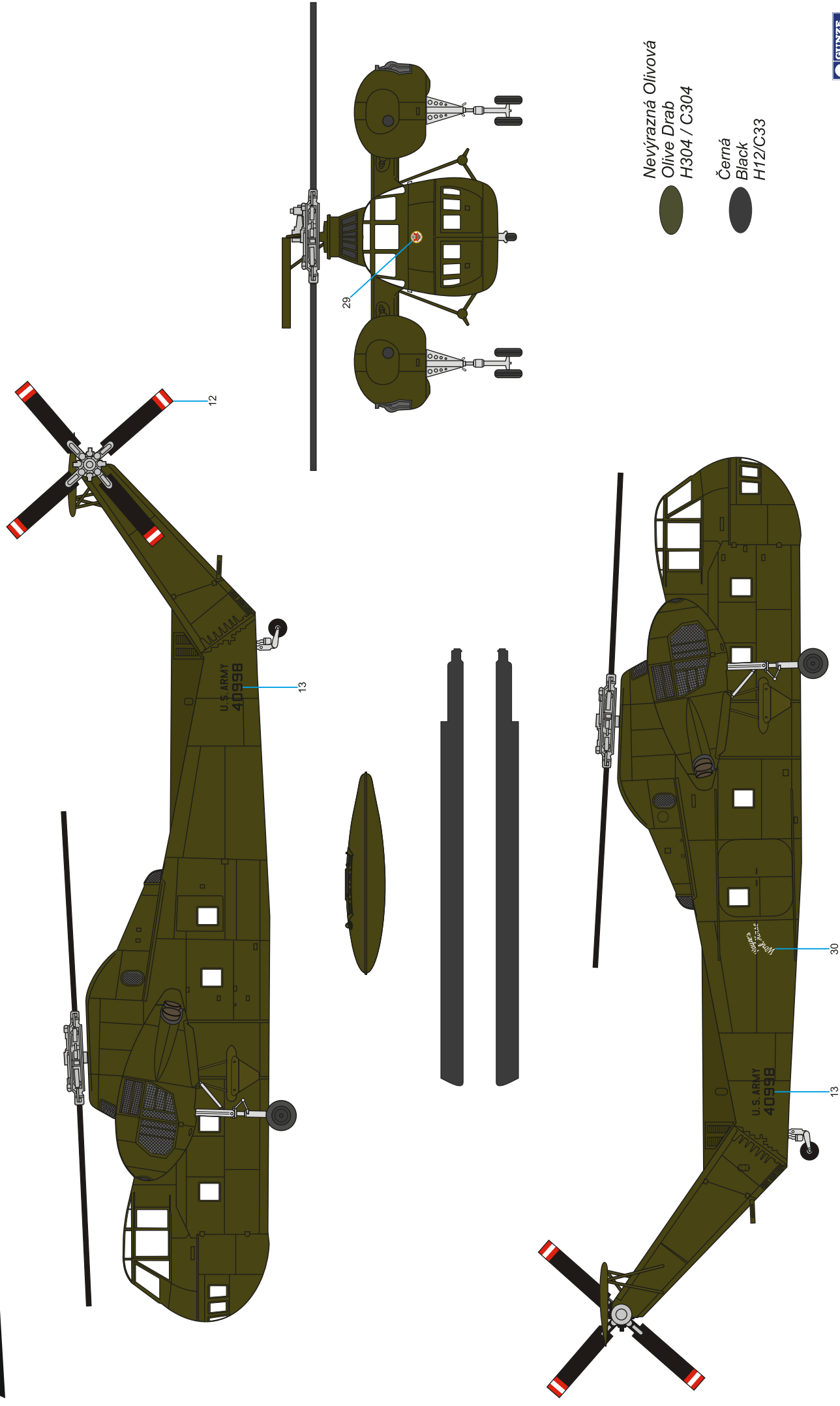

- Nevýrazná Olivová
- Olive Drab H304 / C304
- Černá Black H12/C33

CH-37B Mojave s/n 58-005, "Tired Dude", Illesheim AFB, Germany, 1959. At present this machine is part of the exhibits at the Pima Air and Space Museum, Tuscon, Arizona.
 CH-37B Mojave s/n 58-005, "Tired Dude", základna Illesheim AFB, Německo, 1959. V současnosti je tento stroj exponátem Pima Air and Space Museum, Tuscon, Arizona.

SCHEME C

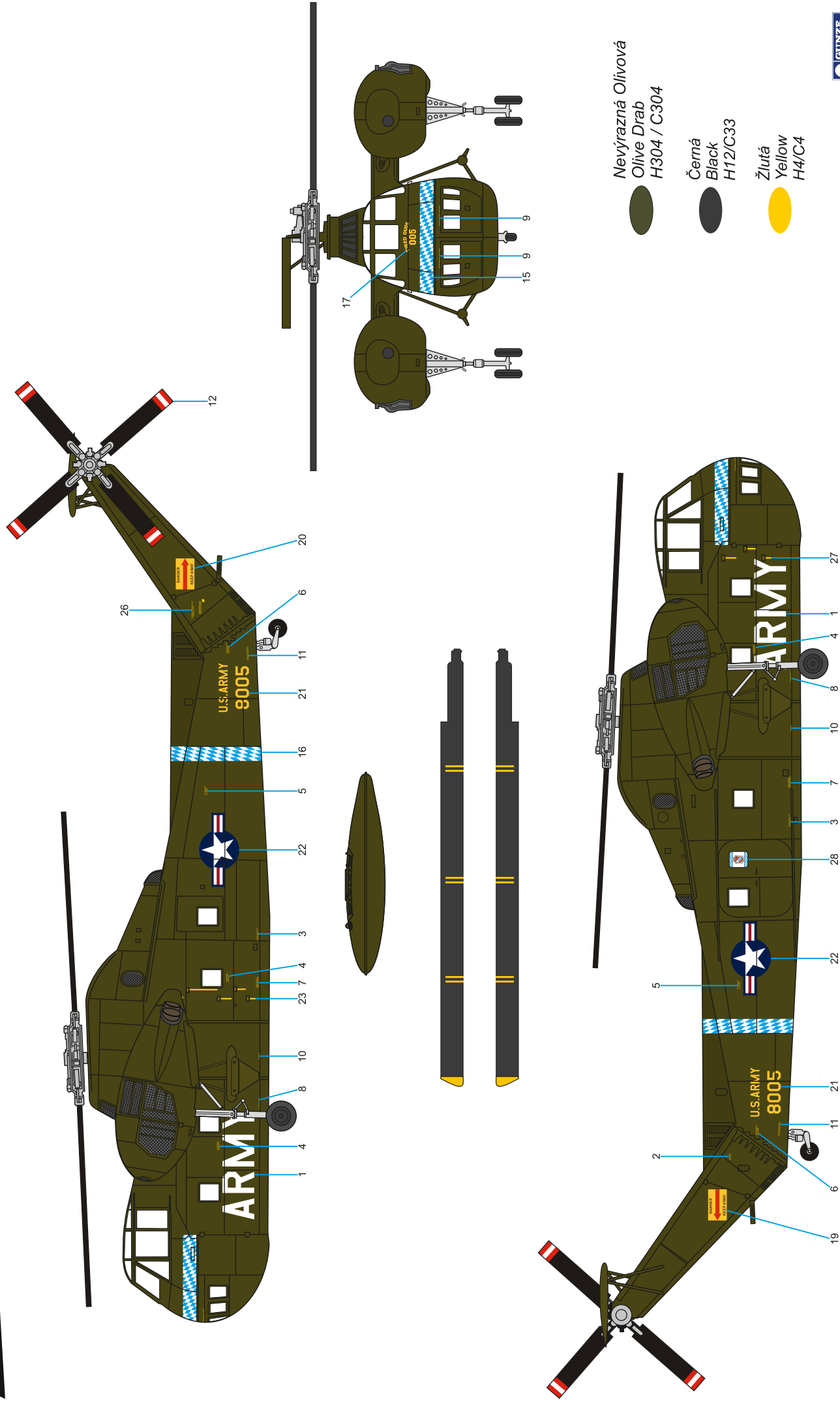

Special Hobby produces not only plastic kits but also resin and 3D printed Planet Models line and others. You can find more information at www.specialhobby.eu

kits, sets and figures in the CMK

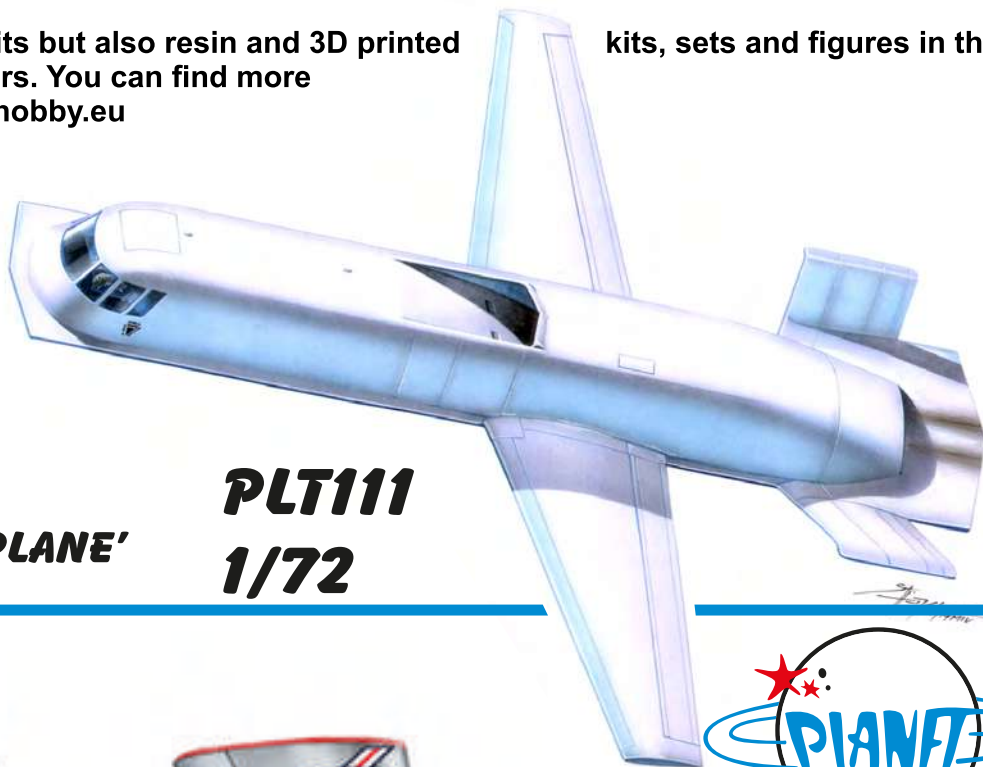

TACIT BLUE
'US STEALTH TEST PLANE'
Resin Kit

PLT111
1/72

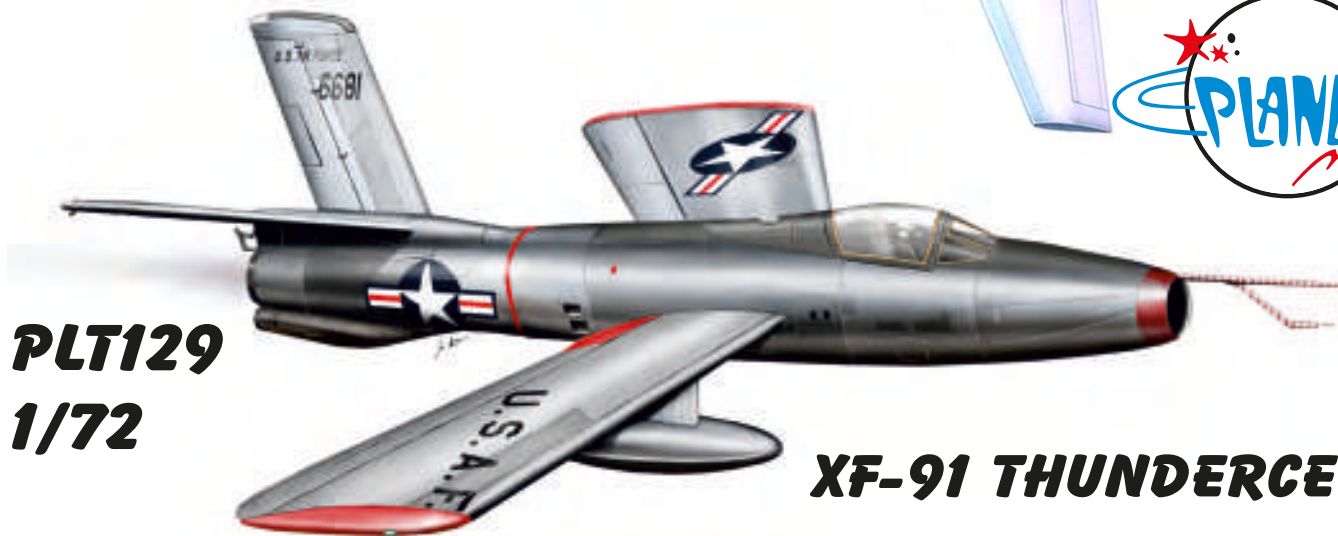

PLT129
1/72

XF-91 THUNDERCEPTOR
Resin Kit

MA-1A USAF Start Cart
7365 1/72

MD-3 Ground Power Unit
7422 1/72

P72019 US Navy Wheel Chocks
1/72 (4 pcs.)

3D-Printed Parts

4x

kolo není součástí setu
wheel not included

1 2

Special Hobby 2024

F72076 1/72
Vietnam LRRP
US Helicopter Crew
(3 figures)



F72080 1/72
UH-1 Helicopter Crew
Vietnam War
(3 figures)



F72111 1/72
US Airborne Vietnam War
(3 figures)



Special
HOBBY
SH72427
1/72



AH-1G Cobra 'Early Tails'

SH72385
1/72



C-41A 'US Transport Plane'

SH72395
1/72



F-84F Thunderstreak 'US Swept-wing Thunder'